

mid Moulding
Innovation
Day 2026

Simulazione dei sistemi di condizionamento

Canali Stefano
Moldex3D Italia

Moldex3D

- Introduzione
- Cooling channel loop wizard
- Conformal cooling wizard
- Enhanced cooling channel wizard
- Conclusioni

- Il raffreddamento influenza notevolmente la solidificazione della parte e questo potenzialmente influisce sulla deformazione che avviene durante e dopo l'estrazione del pezzo dallo stampo.
- Il raffreddamento inoltre occupa il 70%-80% dell'intero tempo di stampaggio; un sistema di raffreddamento ben progettato quindi tenderà ad accorciare il tempo di stampaggio e migliorerà la produzione; al contrario potrebbe essere causa di deformazione, ritiri non uniformi, tensioni residue...

Introduzione

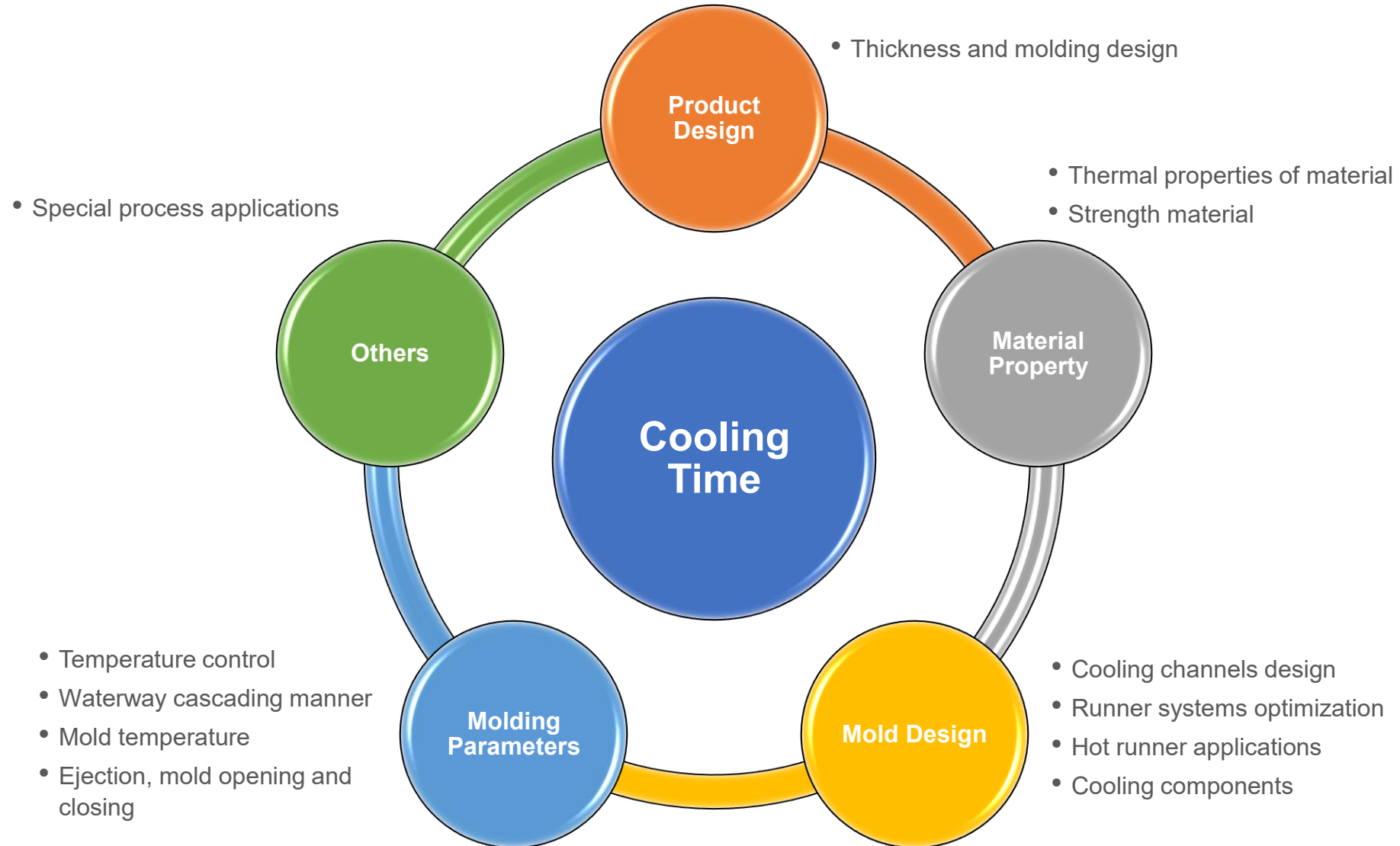

- Tra i fattori che influenzano il cooling time abbiamo visto esserci la modellazione dei componenti del sistema di condizionamento e l'impostazione dei controlli di temperatura e portata.
- Tra le caratteristiche dell'analisi di Moldex3D c'è appunto la possibilità di validare e ottimizzare sia il design che il processo di condizionamento tramite l'analisi di cooling con i transitori termici.
- Qui sotto alcuni esempi delle molteplici funzionalità dell'analisi di cooling di Moldex3D:

- Transient Cool
 - L'analisi di raffreddamento di default in Moldex3D è quella che molto più comunemente è conosciuta come Transient Cool.

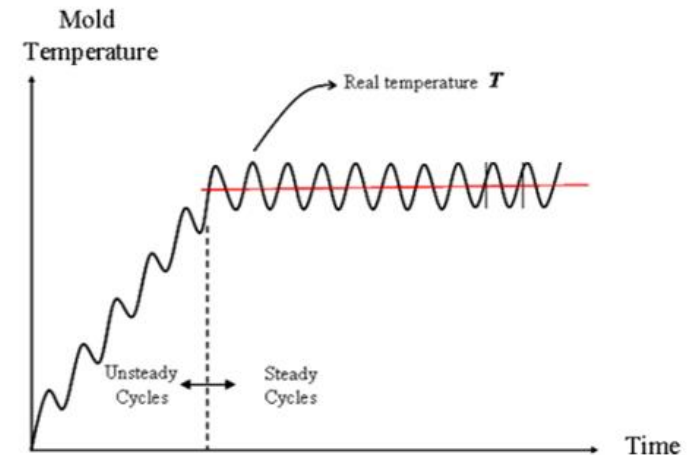
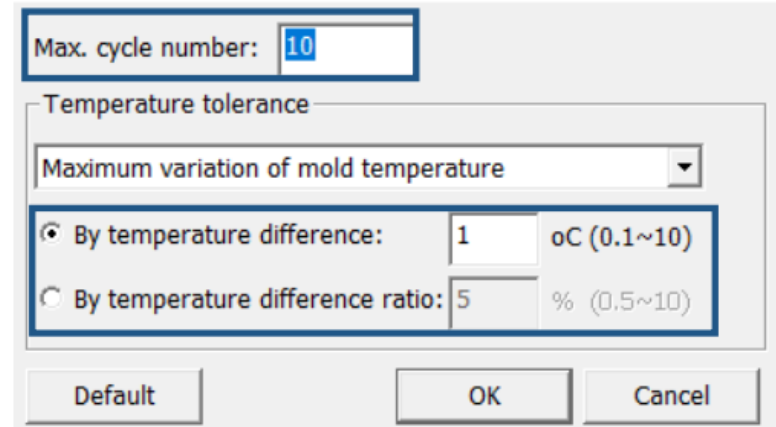
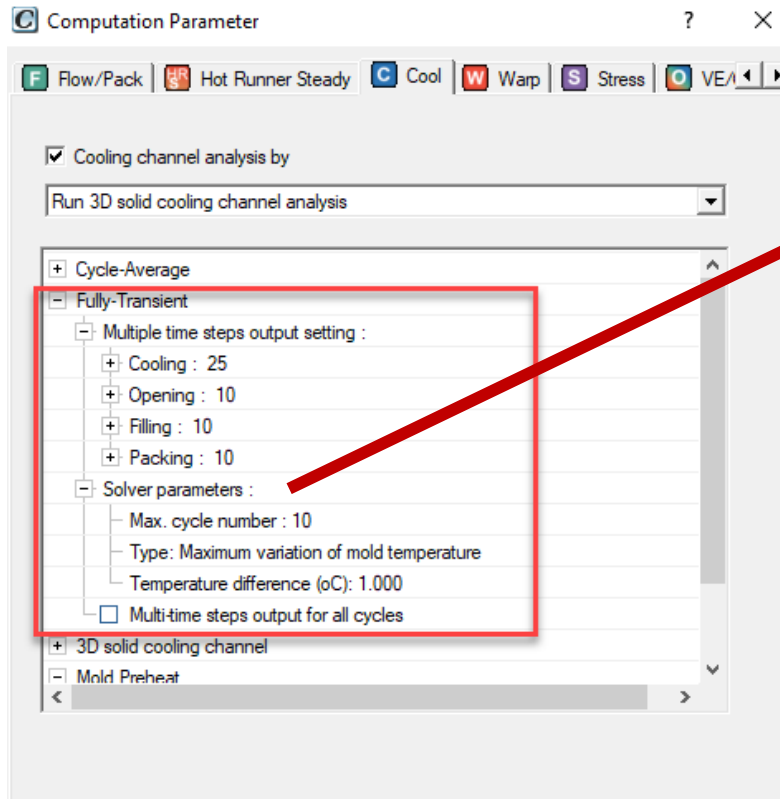
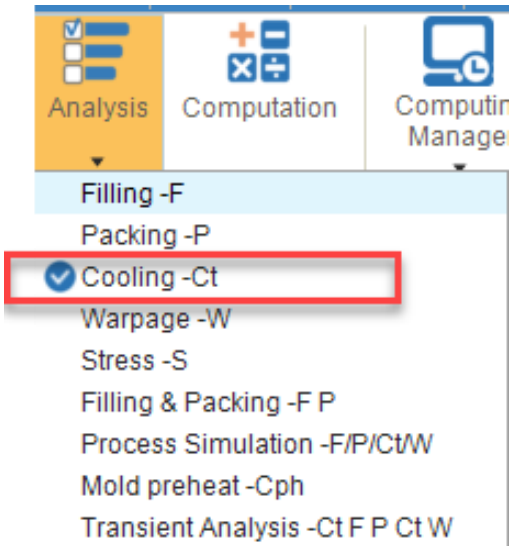

Introduzione

- Metodo di raffreddamento Transient.
 - Possibilità di gestire, grazie all'analisi transient, le variazioni di temperatura all'interno del singolo ciclo.

Moldex3D Process Wizard

Project Settings | Filling/Packing | **Cooling** | Summary

Item	Value	Unit
Cooling method	Transient	
Initial Mold Temperature	60	oC

Cooling / Heating... Mold Metal Material...

Coolant Inlet ID	Control point	Time (sec)	T (oC)	Q (l/min)	Coolant	D (mm)	Re
EC1 (Group 1)	2	0	120	7.2	Water	-	-
	1-1	5	20	7.2	Water	-	-
	1-2	20	120	7.2	Water	-	-

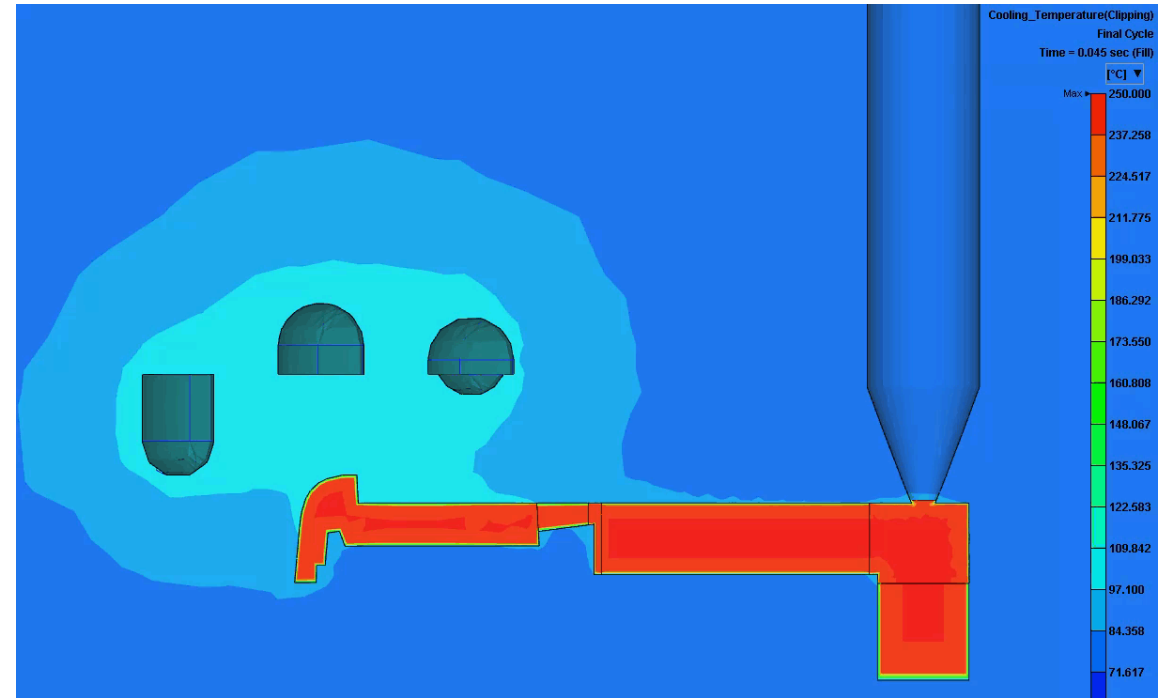
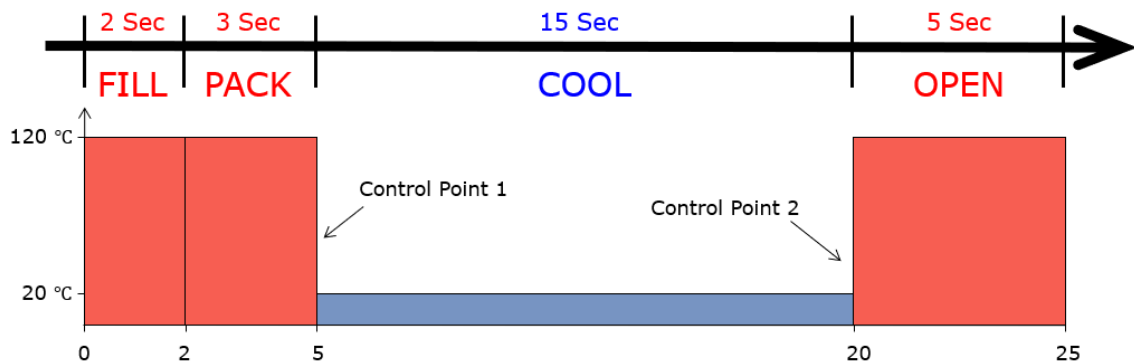

Introduzione

- Metodo di raffreddamento Transient.
 - Variazioni di portata nel ciclo e gestione contemporanea di raffreddamenti e resistenze per temperatura o per potenza.

Coolant Inlet ID	Control point	Time (sec)	T (oC)	Q (l/min)	Coolant	D (mm)	Re
EC1 (Group 1)	2	0	100	0	Water	8	0
	1-1	5	100	40	Water	8	364326
	1-2	12	100	0	Water	8	0
EC2 (Group 2)	2	0	100	0	Water	8	0
	2-1	5	100	40	Water	8	364326
	2-2	12	100	0	Water	8	0

Cooling Advanced Setting

Cooling / Heating | Mold Metal Material | Estimate Cooling Time

Cooling

Setting: By flow rate Machine Interface

Coolant Inlet ID	Control point	Time (sec)	T (oC)	Q (l/min)	Coolant	D (mm)	Re
EC2 (Group 1)	0	0	Refer to Mold Temperature	7.2	Wa...	8	34542
EC3 (Group 2)	0	0	Refer to Mold Temperature	7.2	Wa...	8	34542
EC4 (Group 3)	0	0	Refer to Mold Temperature	7.2	Wa...	8	34542

Apply current setting to group Apply current setting to all

Heating

Heating rod ID	Heating method	Control point	Time (sec)	Value	Unit
RH1	By power	0	0	300.00	W

Temperature Control Setting

Control method: Off

Heating rod ID	Control method	Sensor node ID	Target temper.	Upper Range	Lower Range
RH1	On/Off control PID control		210	5	5

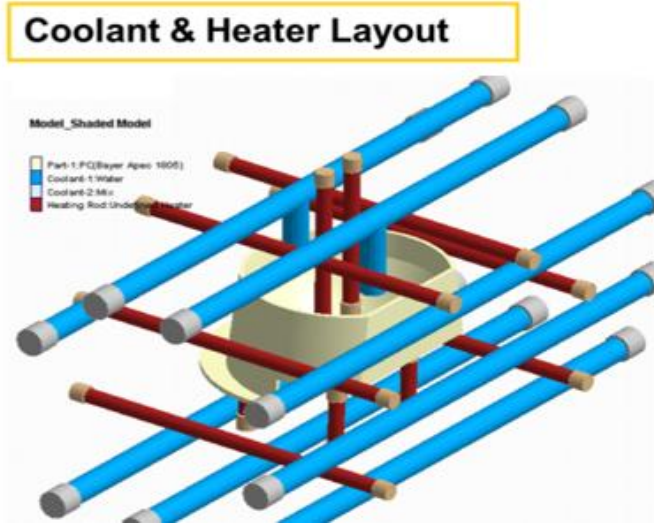
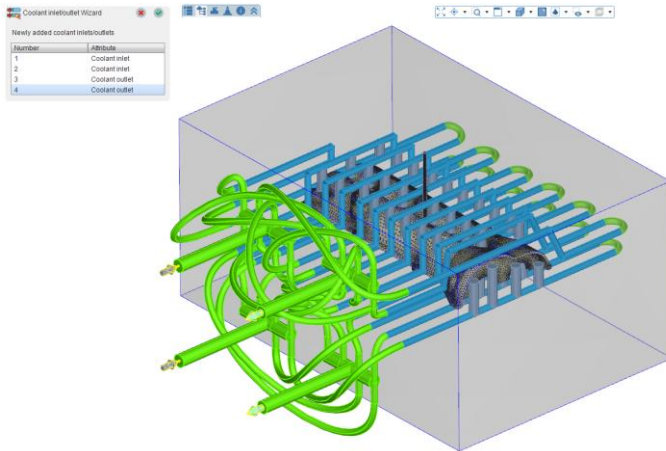

Introduzione

- Cooling channel analysis per raffreddamenti conformali.
 - Prevede le perdite di pressione, la distribuzione di velocità/temperatura all'interno dei canali e gli effetti della rugosità superficiale.

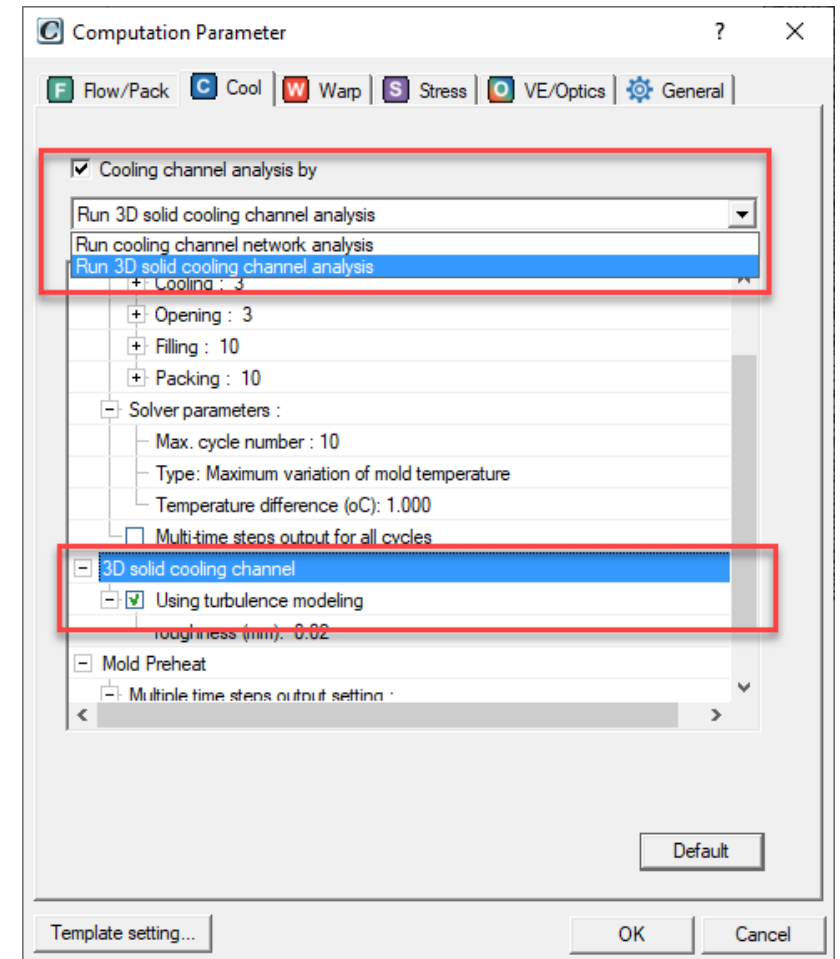
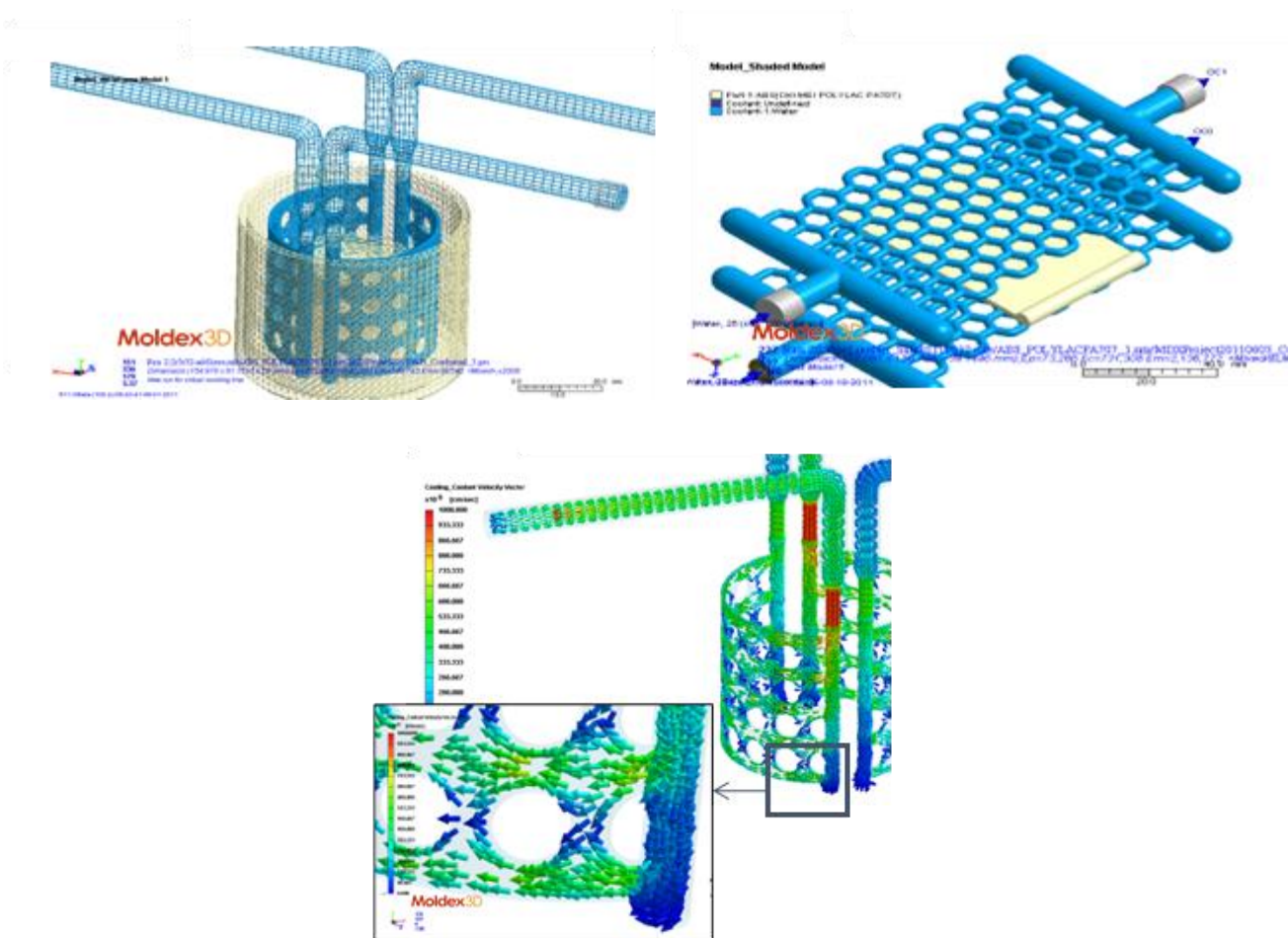

Introduzione

- Simulazione con le piastre dello stampo
 - Analisi termica completa con tutti i componenti 3D dello stampo che hanno un impatto importante sulla distribuzione della temperatura.

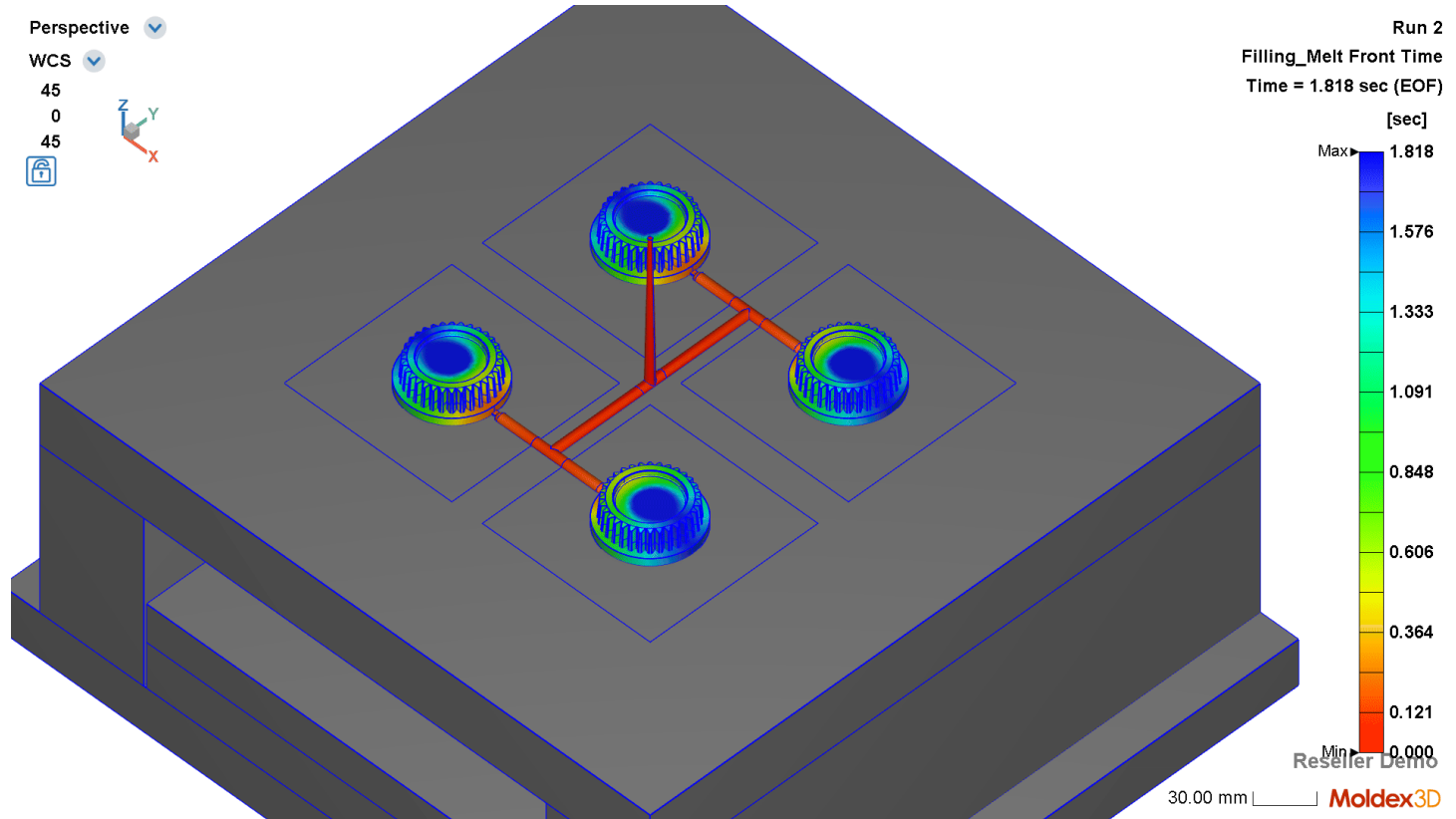
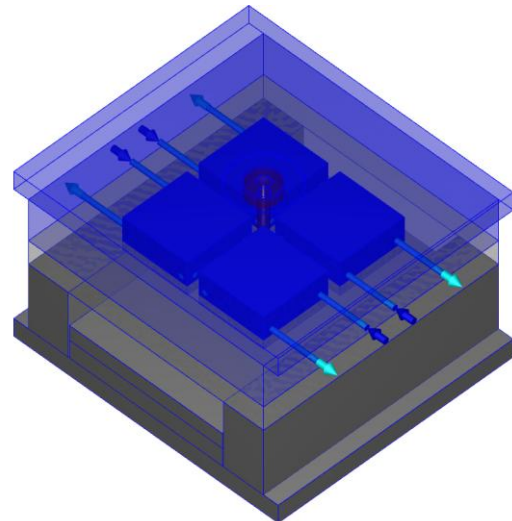
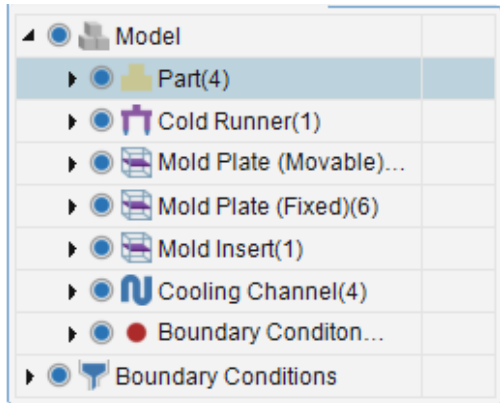

Introduzione

- Simulazione Advanced Hot Runner (AHR)
 - Supporta la modellazione completa della camera calda

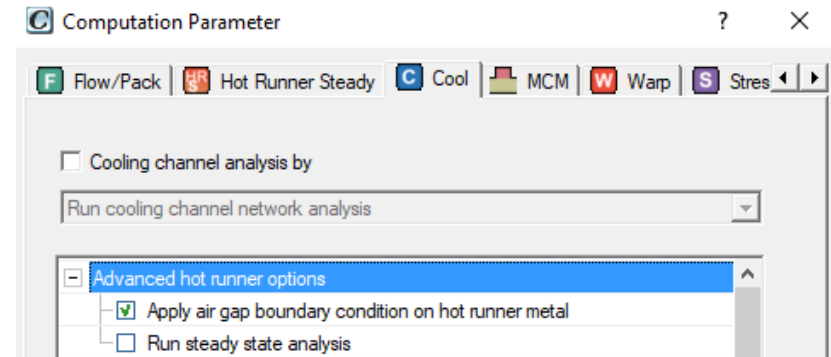
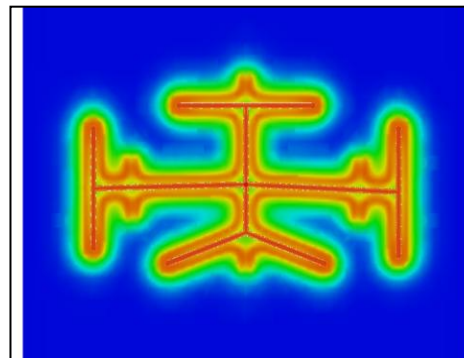
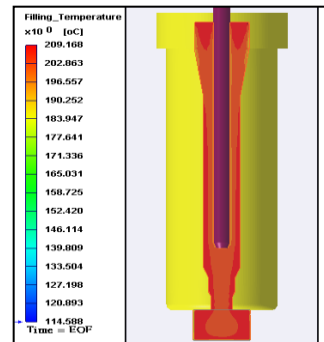
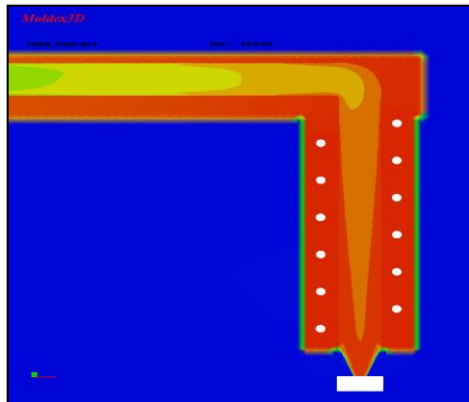
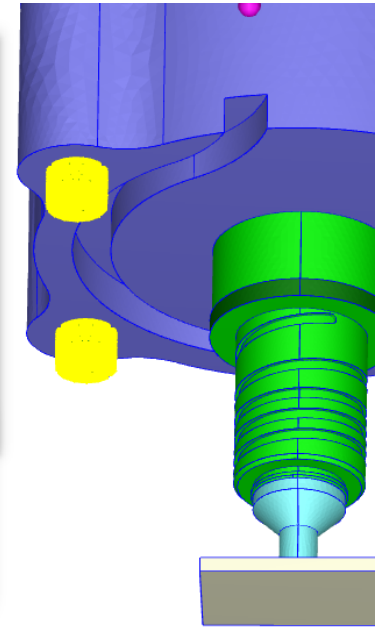
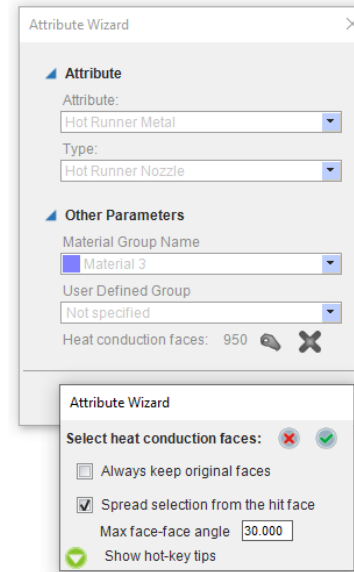
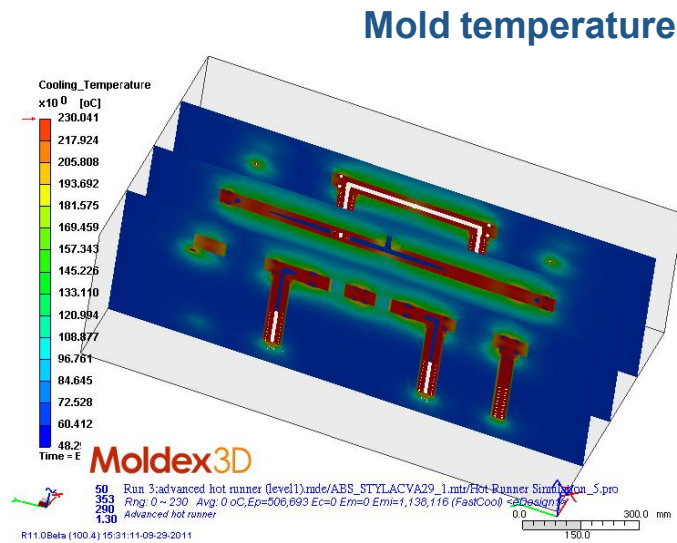
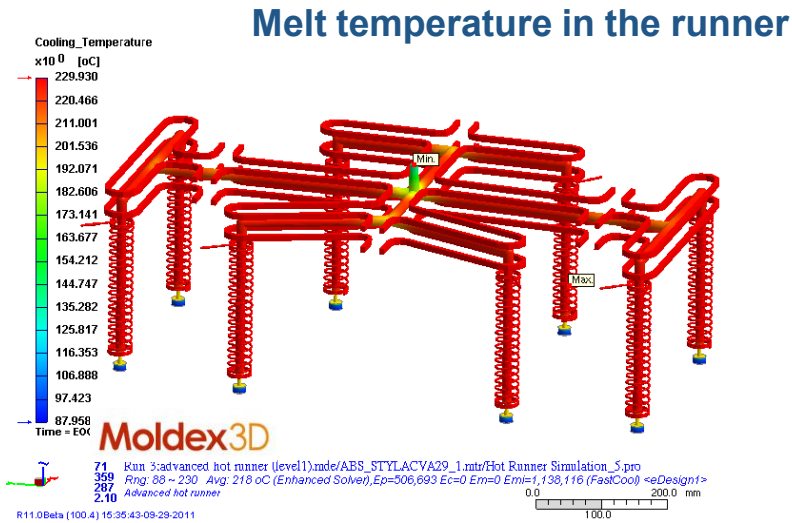

- Cooling channel loop wizard
- Conformal cooling wizard
- Enhanced cooling channel wizard

Cooling channel loop wizard

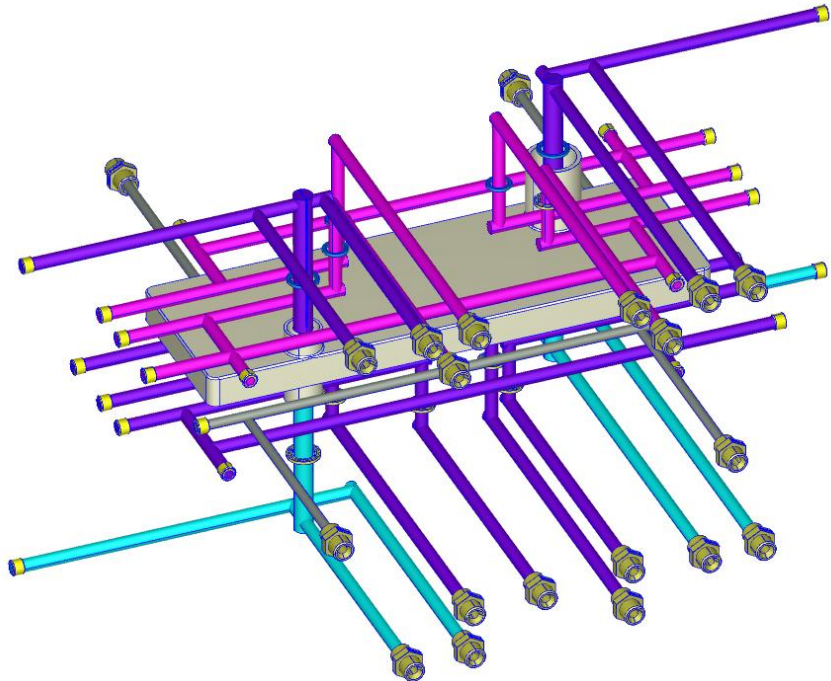
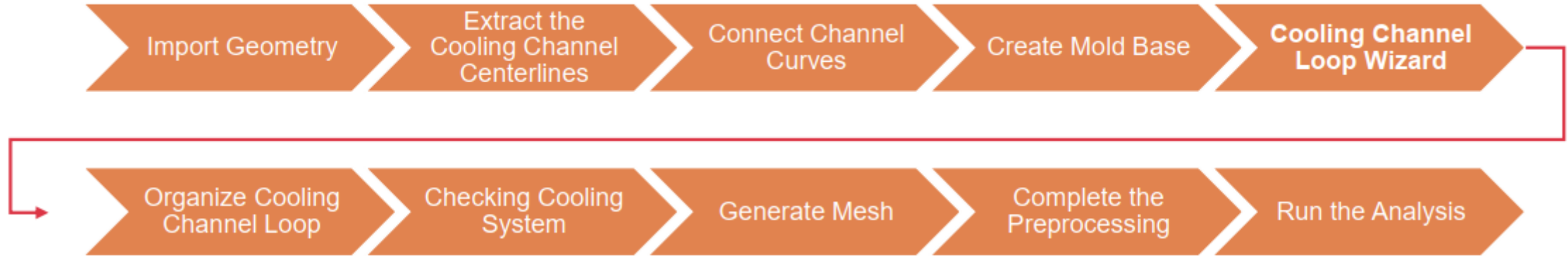

La funzione Cooling channel loop wizard offre un modo efficiente per definire e organizzare le curve dei circuiti di raffreddamento quando si gestiscono sistemi di raffreddamento 3D complessi, riducendo significativamente i tempi necessari rispetto all'utilizzo di strumenti geometrici tradizionali.



Cooling channel loop wizard

Importare il file STEP
con la funzione Auto-Heal



IMPORT

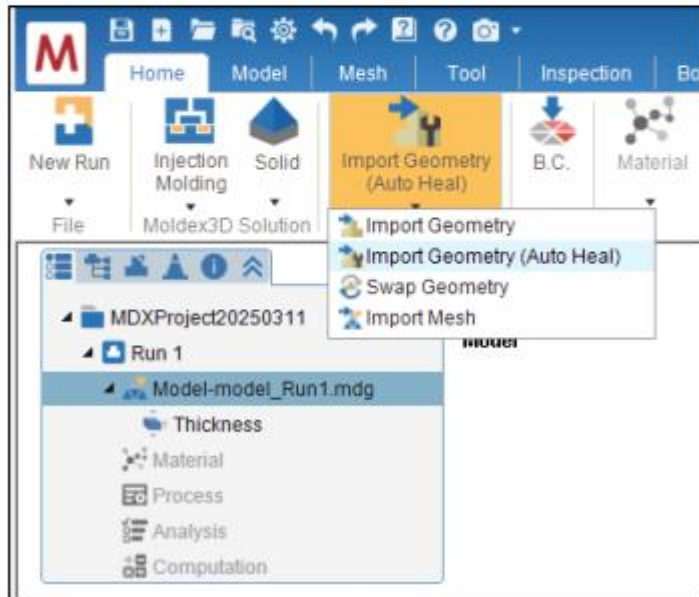

Se non fatto in precedenza filtrare o eliminare le
piastre non necessarie, cominciare ad assegnare le
parti.

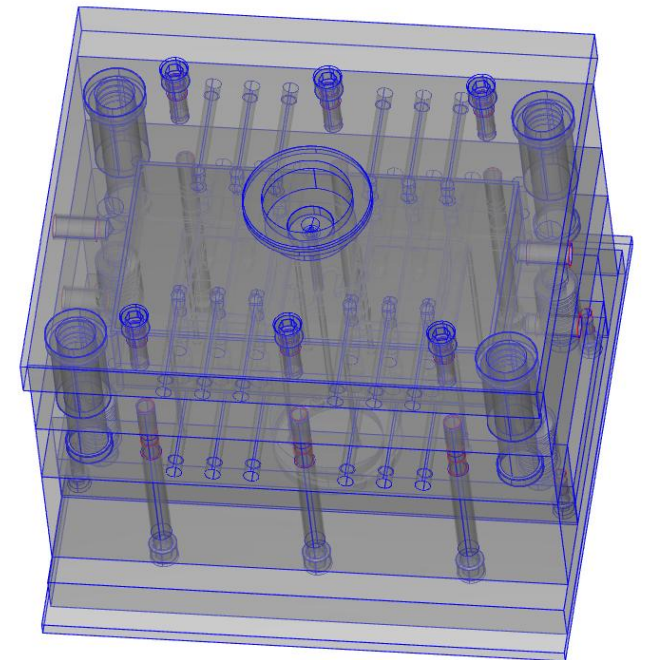
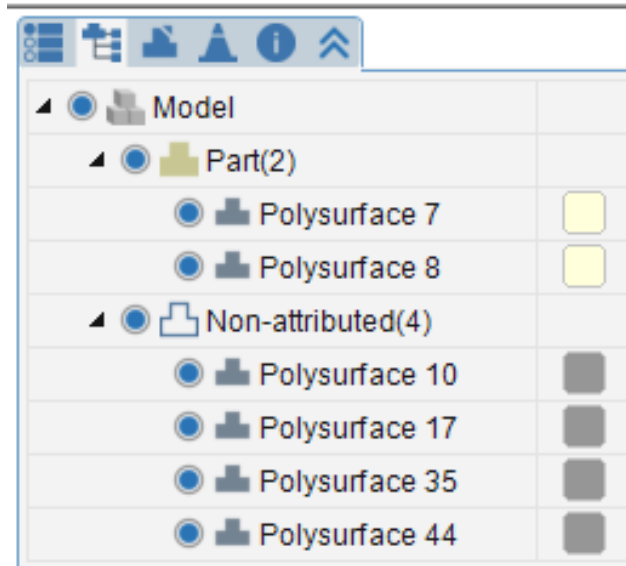

Cooling channel loop wizard

Fai clic su 'Center Line' e selezionare le piastre con i canali di raffreddamento per estrarre le linee centrali di ciascun canale circolare.

- Si può anche attivare la modalità 'Add to group': dopo aver fatto clic su OK, il sistema raggrupperà i canali in base ai criteri selezionati.
- Attualmente, l'estrazione della linea centrale è supportata per canali o fori di raffreddamento circolari 3D.

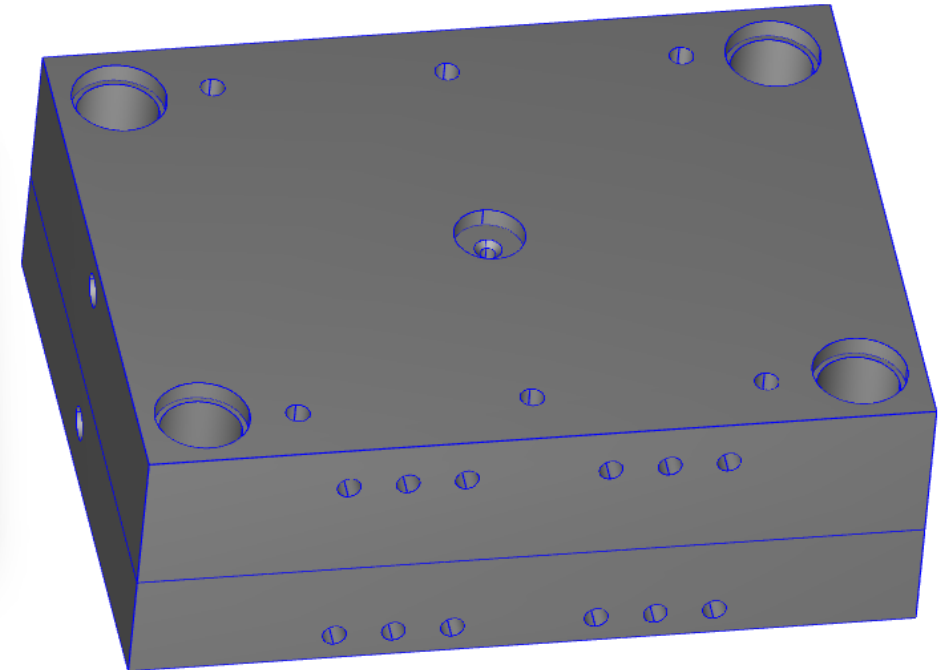
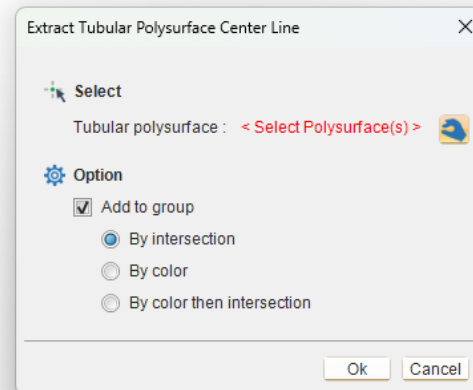
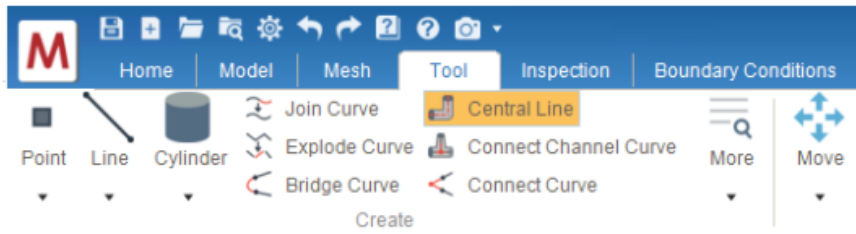

Cooling channel loop wizard

Mantenere gli assi centrali dei canali di raffreddamento ed eliminare le curve non necessarie

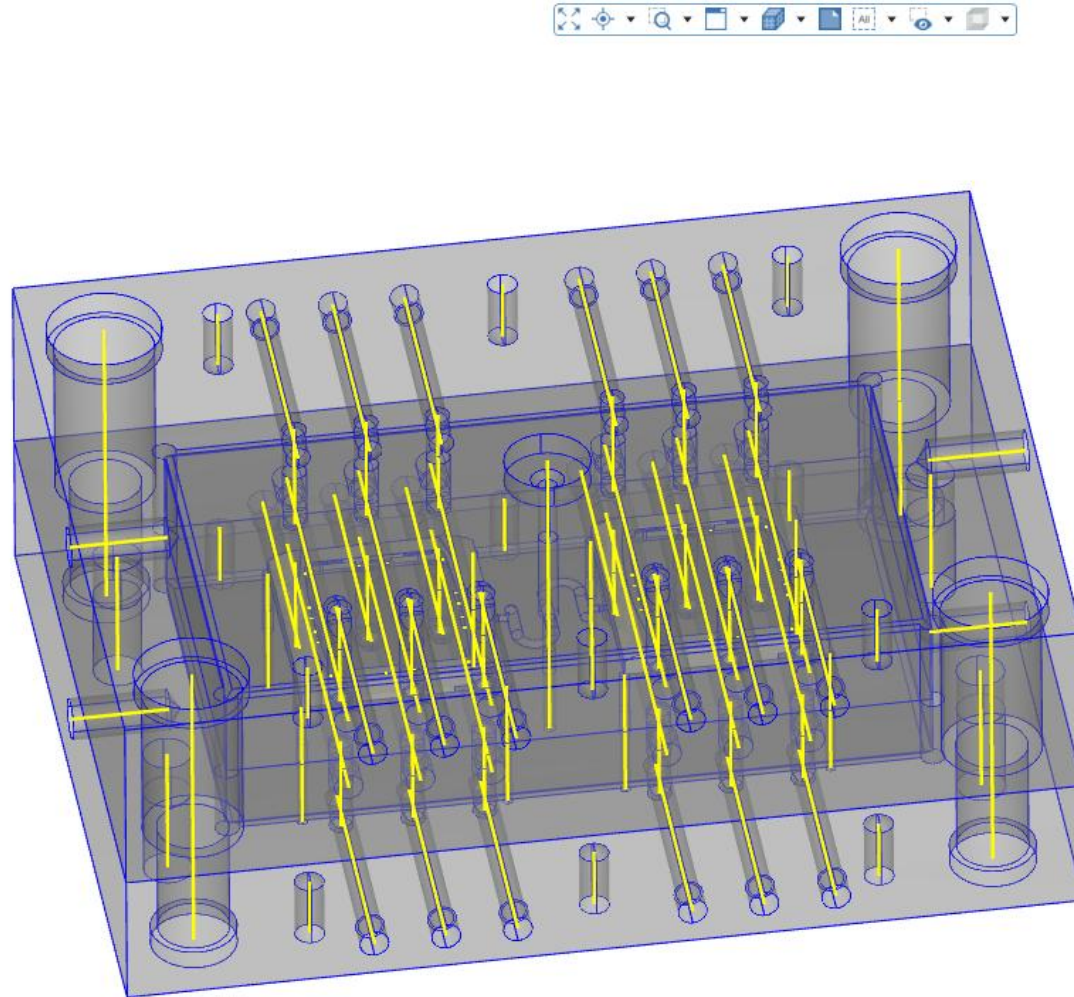
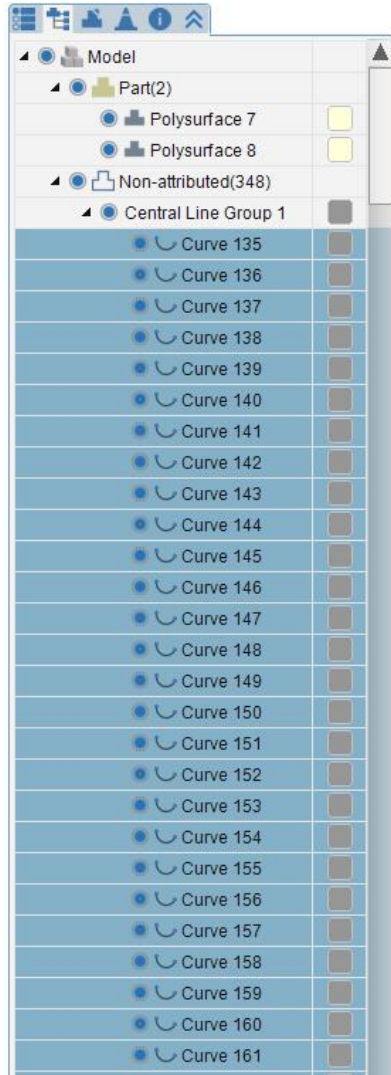

Cooling channel loop wizard

Cliccare su 'Connect Channel Curve', quindi selezionare gli assi generati in precedenza.

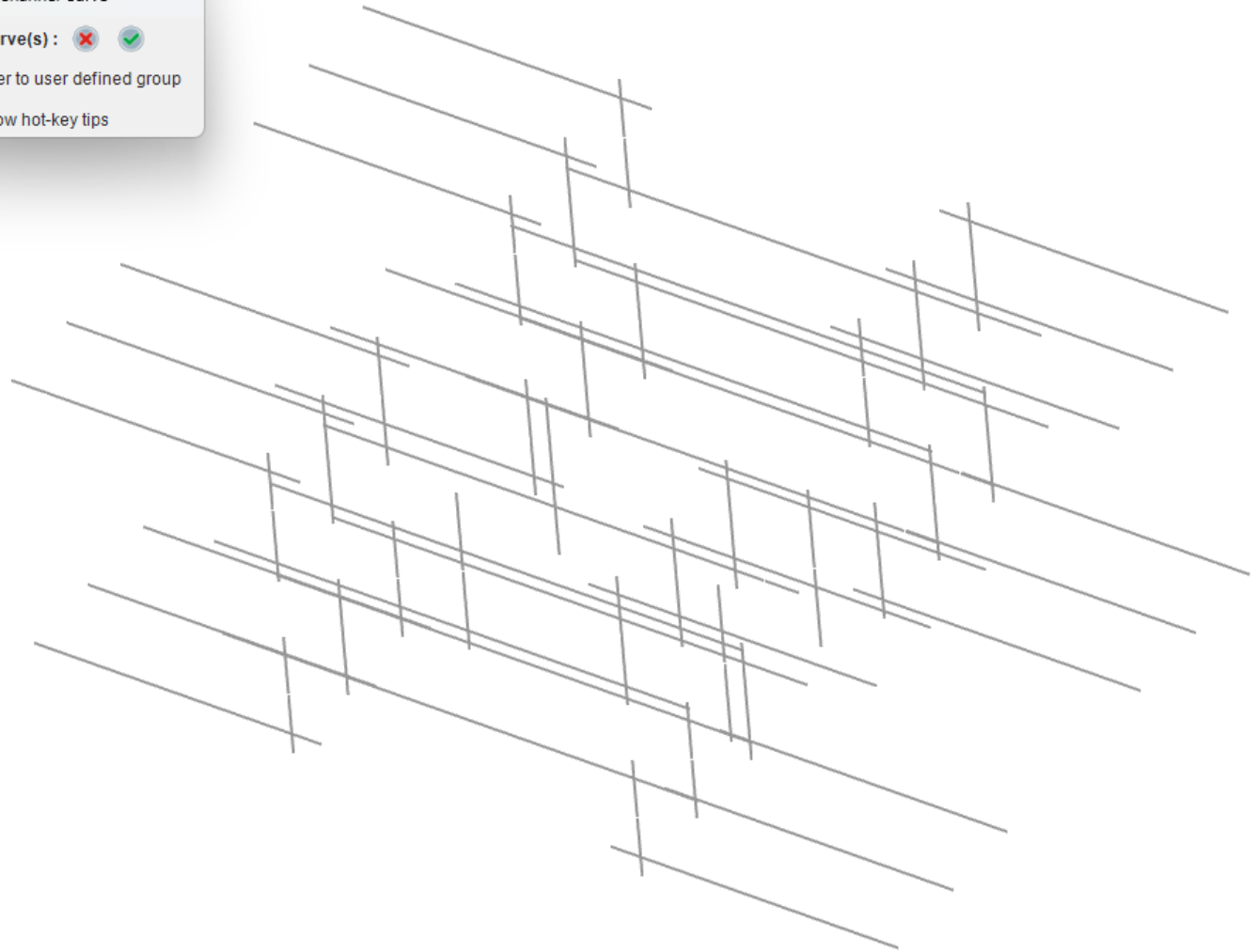
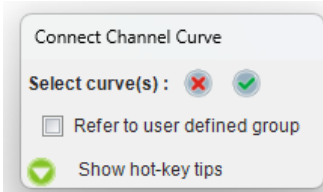
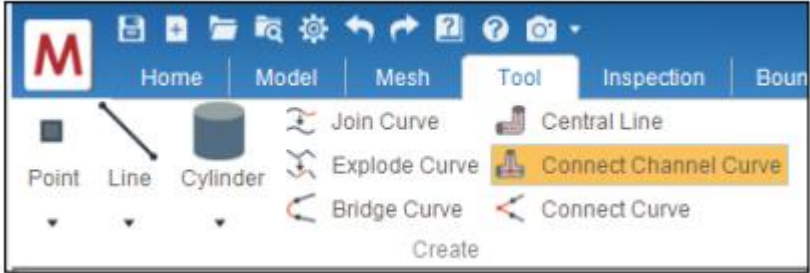

Cooling channel loop wizard

Creare il moldbase con la funzione classica o tramite la funzione 'Bounding Box' altrimenti non si attiva la funzione Loop Wizard

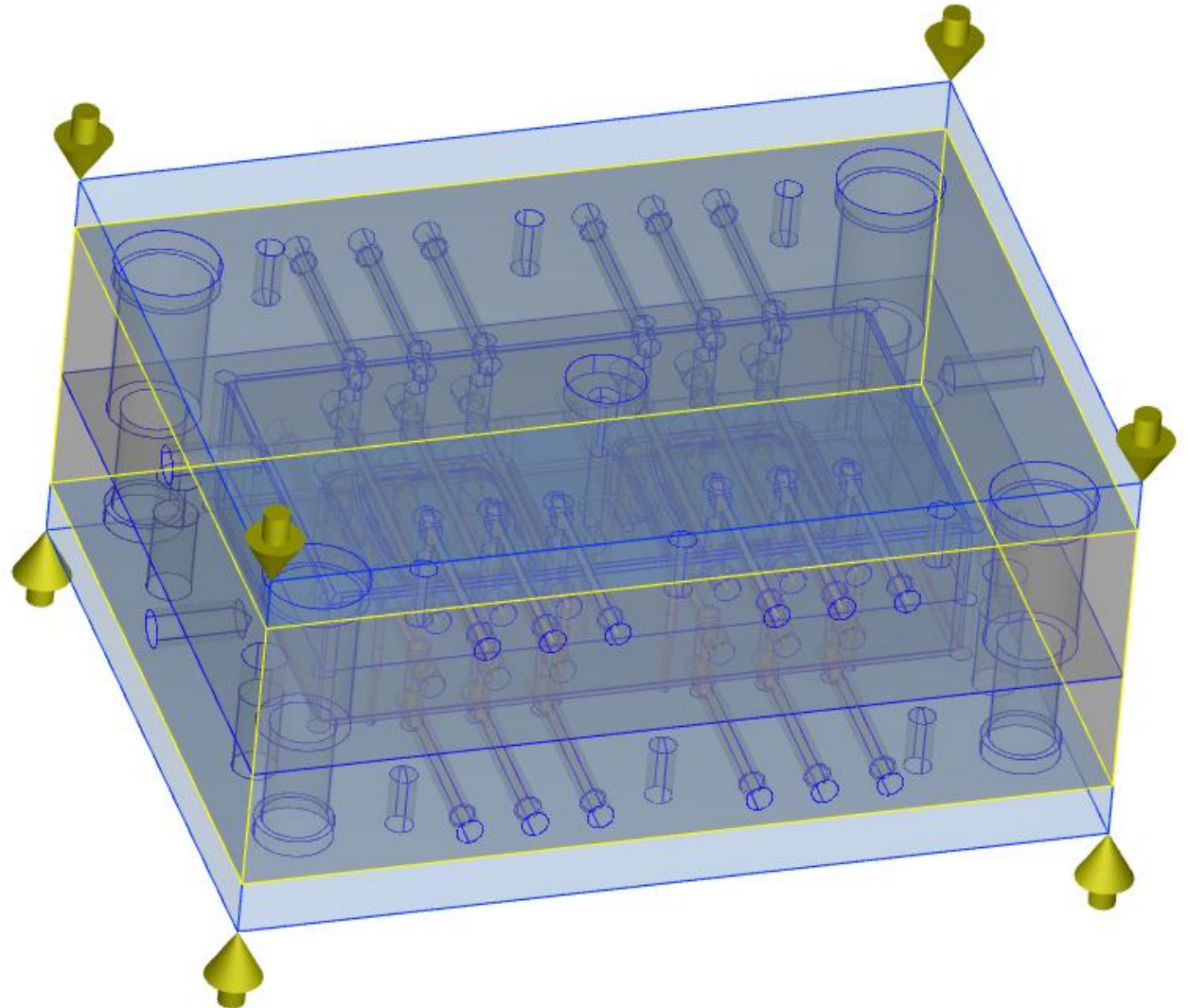
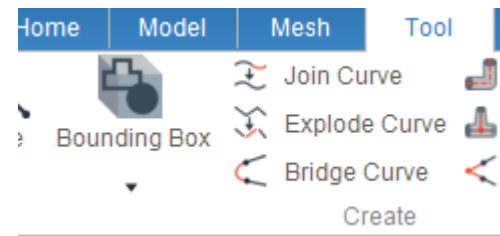
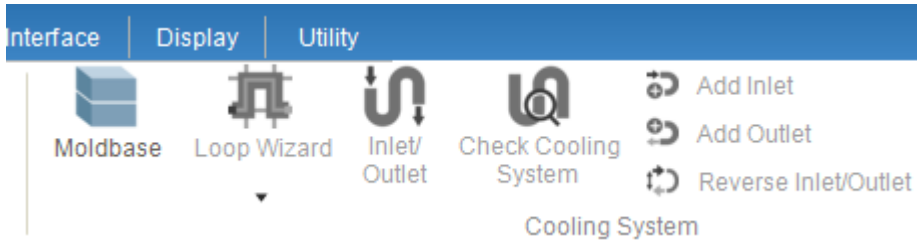

Cooling channel loop wizard

Cliccare sulla funzione Loop Wizard e selezionare le curve che fanno parte del primo loop.

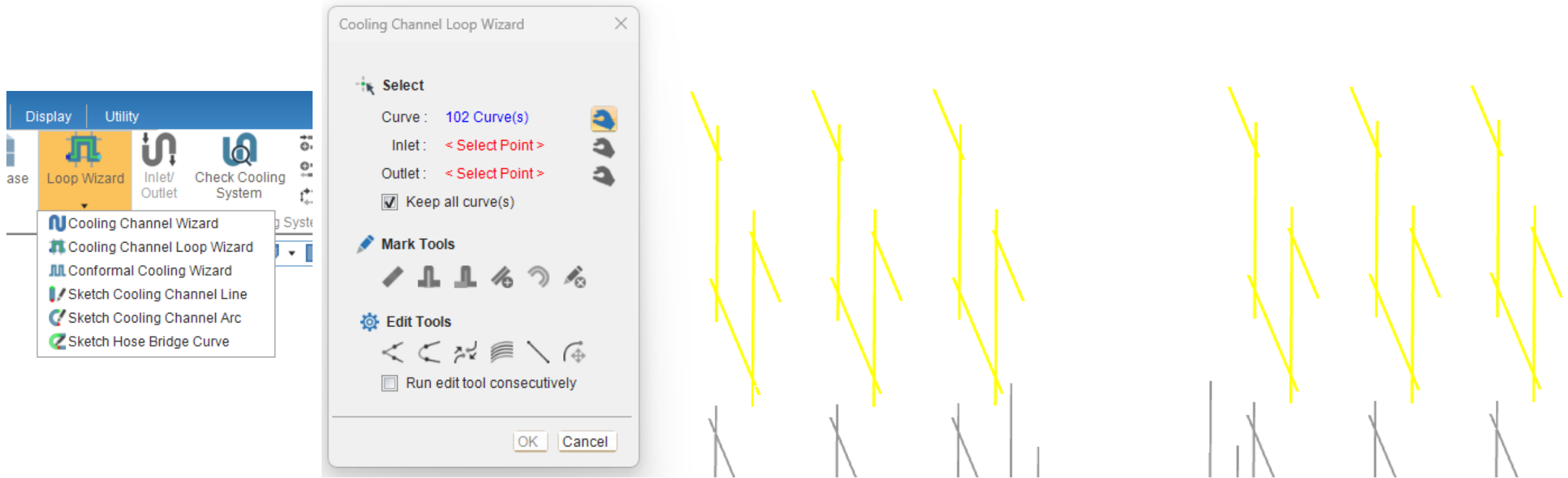

Cooling channel loop wizard

Selezionare il punto di entrata e di uscita e contrassegnare eventuali fontane, pozzetti, tappi o tubature esterne. Con gli strumenti di edit posso anche disegnare entità 'al volo'.

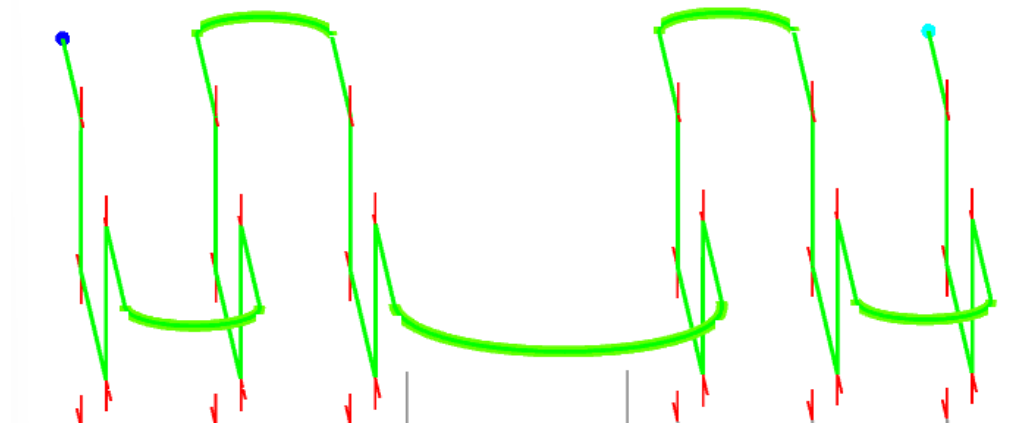
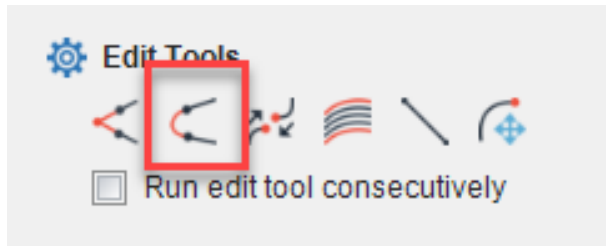
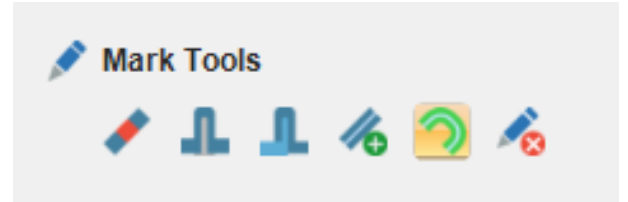
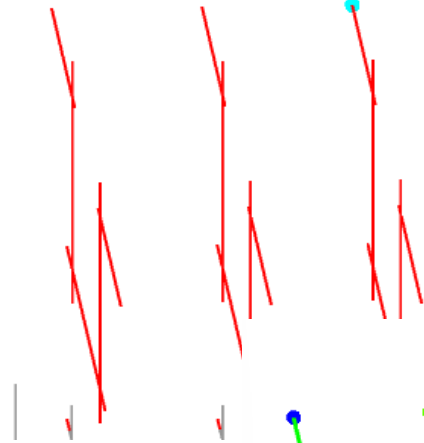
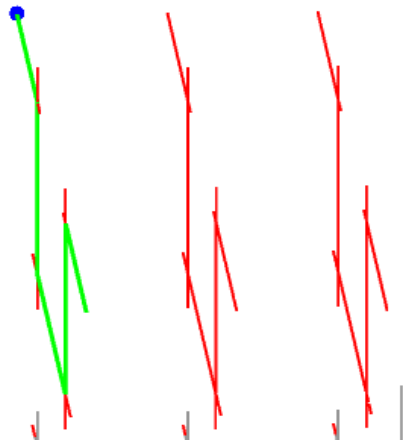
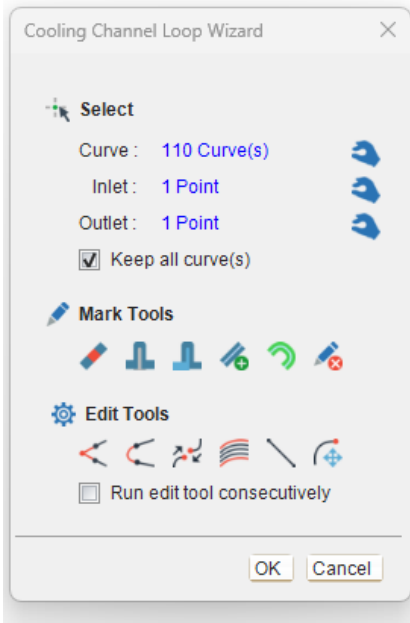

Cooling channel loop wizard

Risultato finale

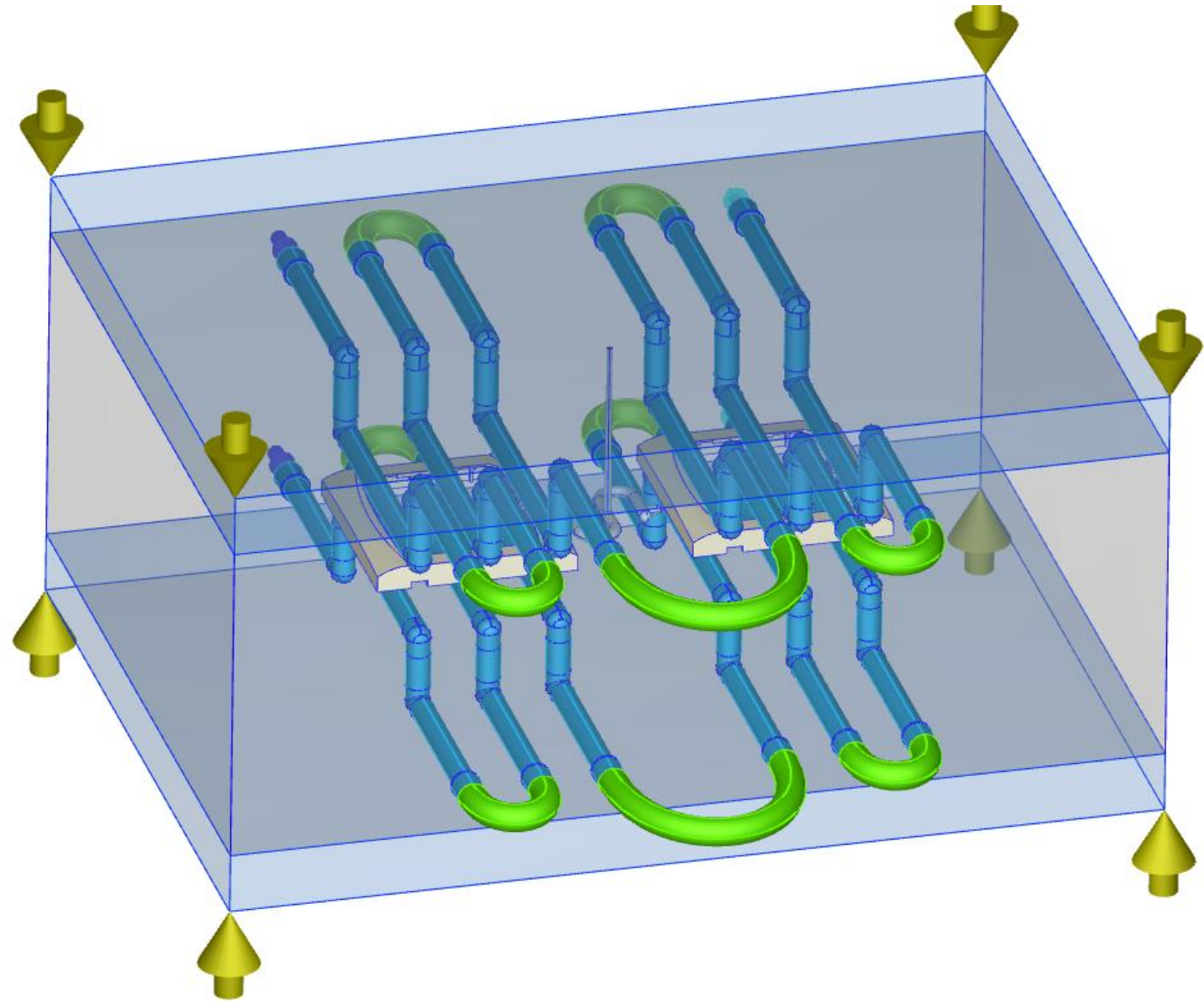

Cooling channel loop wizard

The screenshot displays the Moldex3D Studio 2026 interface for the Cooling Channel Loop Wizard. The main window shows a 3D model of a mold cavity with cooling channels. The interface includes a ribbon with various toolbars (Import and Analysis, Runner System, Cooling System, Special Molding, Advisor), a left-hand tree view, a top navigation bar, and a right-hand coordinate system panel. The status bar at the bottom shows 'Command < Close WIZARD >' and a scale of 40.00 mm.

MDXProject20260520 - Moldex3D Studio 2026

Home | Model | Mesh | Tool | Inspection | Boundary Conditions | Template | FEA Interface | Display | Utility

Import and Analysis: Import Geometry (Auto Heal), Check Geometry, Attribute, Model Thickness

Runner System: Gate, Runner Line, Melt Entrance, Specify Point, Specify Face, Symmetry, Path Length

Cooling System: Moldbase, Loop Wizard, Inlet/Outlet, Check Cooling System, Add Inlet, Add Outlet, Reverse Inlet/Outlet, Align Inlet/Outlet

Special Molding: Preview Joint, Nozzle Zone, Compression Zone

Advisor

Tree View: MDXProject20260520 > Run 1 > Model-model_Run1.mdg > Thickness > Material > Process > Analysis > Computation

Coordinate System: Perspective, WCS, 152, 286, 174

Run 1 Model

Status Bar: Command < Close WIZARD > 40.00 mm | Moldex3D

Cooling channel loop wizard

MDXProject20260514 - Moldex3D Studio 2026

Home Model Mesh Tool Inspection Boundary Conditions Template FEA Interface Display Utility

Import Geometry Check Geometry Attribute Model Thickness Gate Runner Melt Entrance Specify Point Path Length Specify Face Symmetry Moldbase Loop Wizard Inlet/Outlet Check Cooling System Add Inlet Add Outlet Reverse Inlet/Outlet Align Inlet/Outlet Preview Joint Nozzle Zone Compression Zone Advisor

Import and Analysis Runner System Cooling System Setting Special Molding Advisor

Model

- Part(1)
- Polysurface 5363
- Non-attributed(127)
- Polysurface 5235
- Polysurface 5236
- Polysurface 5237
- Polysurface 5238
- Polysurface 5239
- Polysurface 5240
- Polysurface 5241
- Polysurface 5242
- Polysurface 5243
- Polysurface 5244
- Polysurface 5245
- Polysurface 5246
- Polysurface 5247
- Polysurface 5248
- Polysurface 5249
- Polysurface 5250
- Polysurface 5251
- Polysurface 5252
- Polysurface 5253
- Polysurface 5254
- Polysurface 5255
- Polysurface 5256
- Polysurface 5257
- Polysurface 5258
- Polysurface 5259
- Polysurface 5260
- Polysurface 5261
- Polysurface 5262
- Polysurface 5263
- Polysurface 5264
- Polysurface 5265

Perspective WCS 61 359 83

Run 4 Model

Reseller Demo 30.00 mm Moldex3D

Command < Moldbase Wizard >

Conformal cooling wizard

Anteprima dei canali di condizionamento:

- I risultati vengono visualizzati in tempo reale.

Mostra l'offset dell'oggetto:

- Disponibile solo durante l'anteprima dei canali di raffreddamento.
- Mostra l'offset dell'oggetto quando selezionato.

Impostazione della trasparenza:

Intervallo 0–100

Rende gli oggetti di offset semi-trasparenti per visualizzare meglio il modello originale.

Impostazioni dei parametri:

Sono stati aggiunti le frecce per le regolazioni.

I valori possono anche essere modificati utilizzando la rotella del mouse.

Barra di Progresso:

Mostra i progressi attuali dei calcoli.

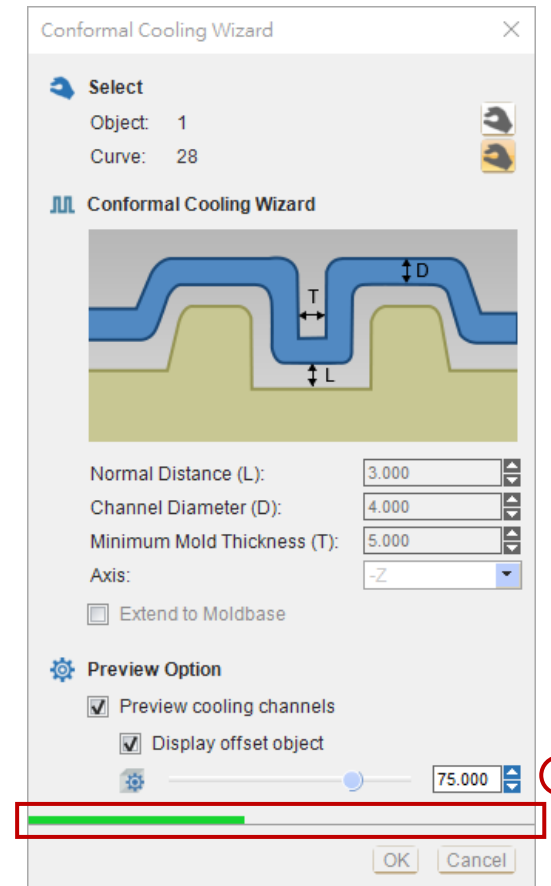
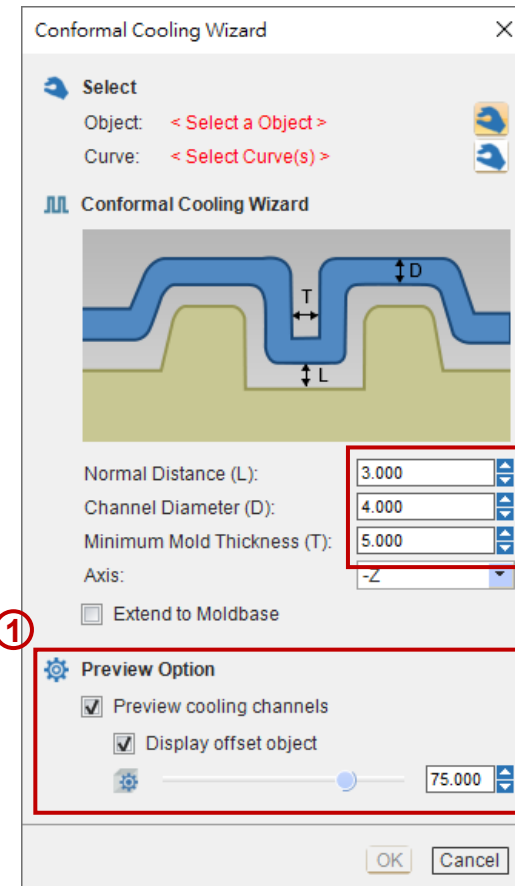
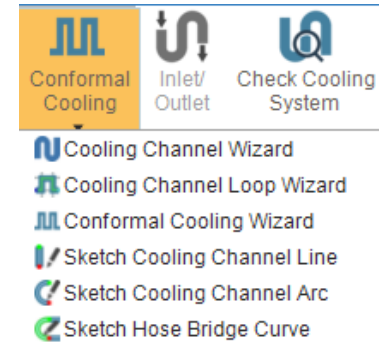

Conformal cooling wizard

- **Panoramica dell'anteprima :**

- Abilita l'anteprima dopo aver selezionato oggetti o curve per visualizzare istantaneamente i risultati

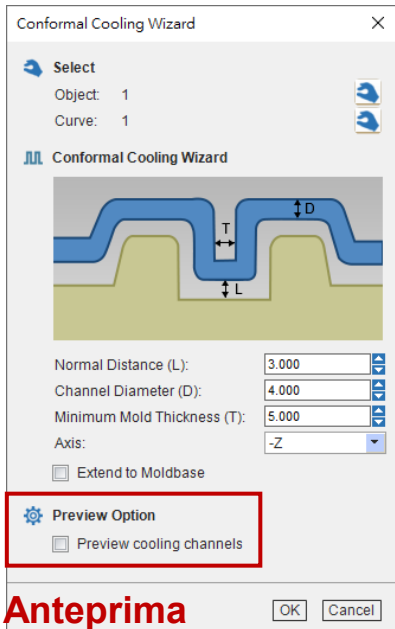

Anteprima disattivata

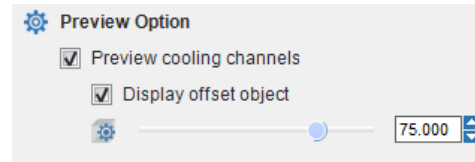
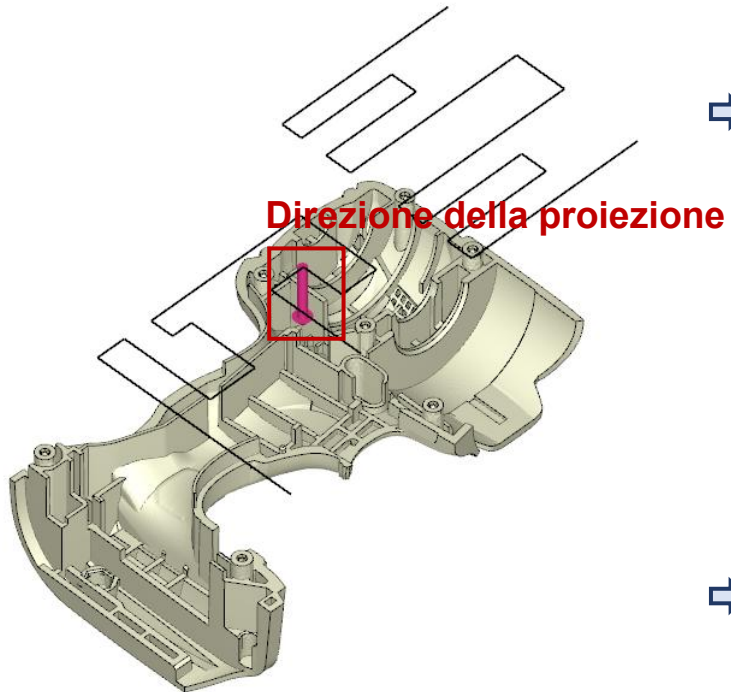

Canali + Offset oggetto

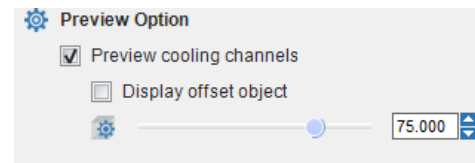
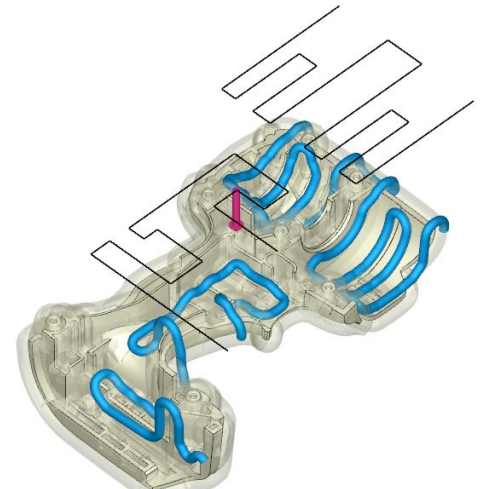

Solo canali

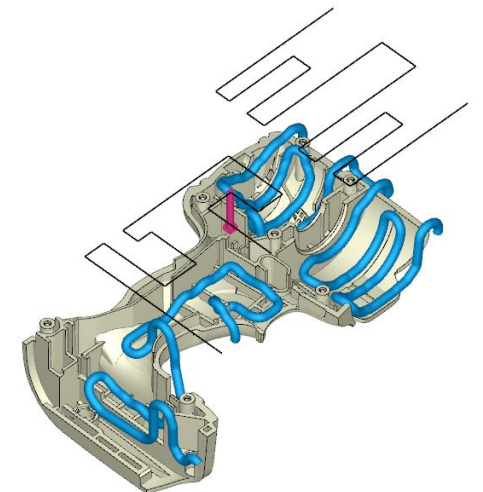

Conformal cooling wizard

- Panoramica del controllo degli errori:

- 1. Errore di proiezione della curva:

- Le curve connesse sono raggruppate; se un gruppo non può essere proiettato, viene segnalato.

- Durante l'anteprima:

- Le aree problematiche sono evidenziate in rosso: messaggio di errore visualizzato in basso a sinistra.

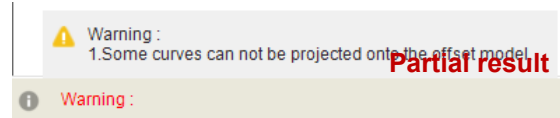
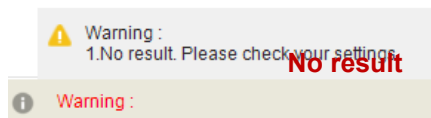

- Dopo aver confermato "Ok":
Avviso popup.

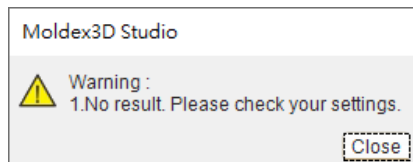

No result

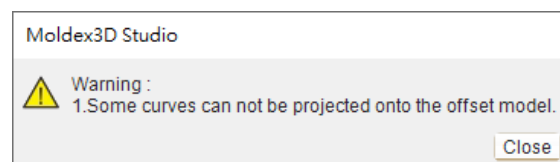

Partial result

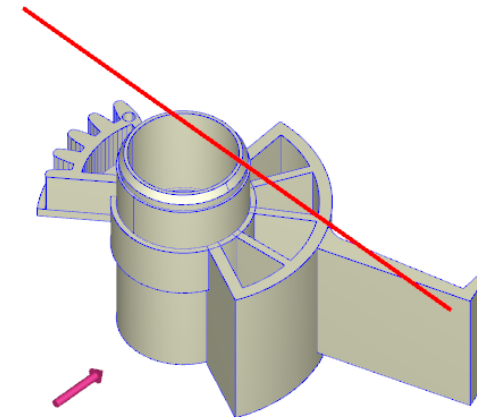

Conformal cooling wizard

- Panoramica del controllo degli errori:
 - 2. Alcuni segmenti di curva intersecano l'offset dell'oggetto:

- L'intersezione può causare problemi di proiezione.
- Suggerisce di regolare le posizioni delle curve.

- Durante l'anteprima:

- Le aree problematiche sono evidenziate in rosso.
- Messaggio di errore visualizzato in basso a sinistra.

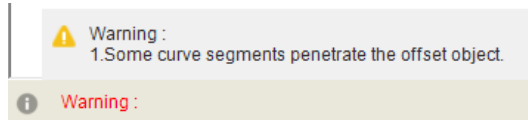

- Dopo aver confermato "Ok":
 - Avviso popup.
 - Curve problematiche sono inserite in un gruppo designato.

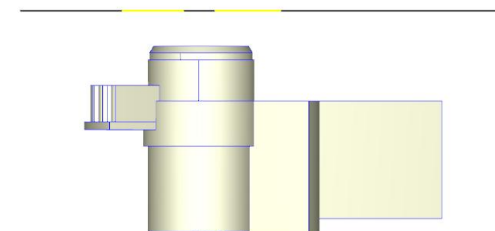
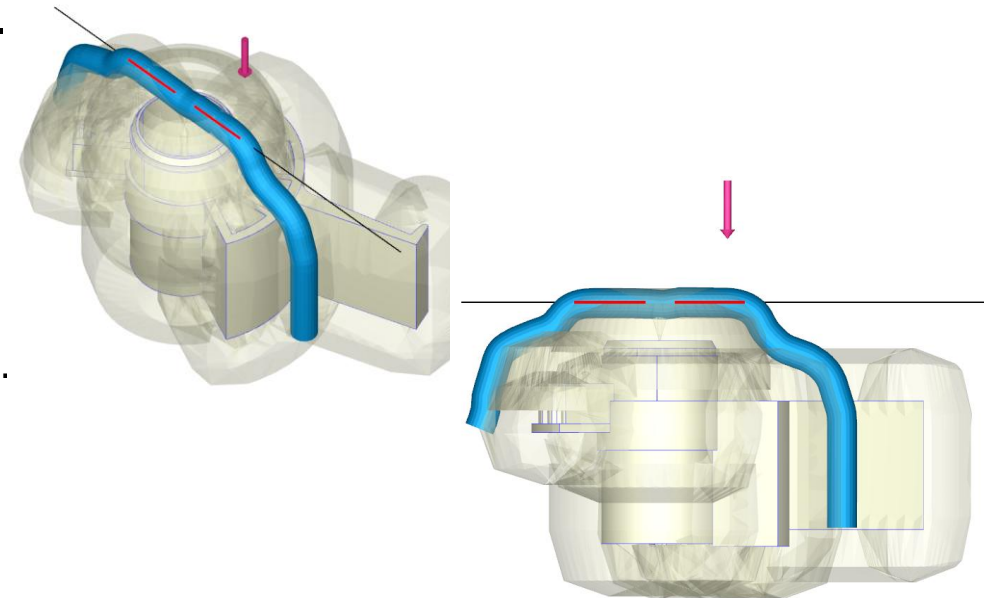
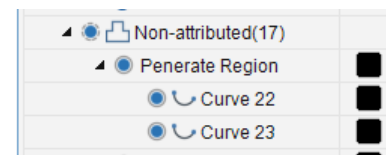
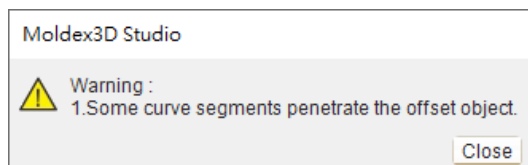

Conformal cooling wizard

- Panoramica del controllo degli errori:
 - 3. Il canale di raffreddamento interseca con l'oggetto target :
 - Regola la distanza normale, il diametro o lo spessore minimo dello stampo se si intersecano.
 - 4. Ci sono canali di raffreddamento sovrapposti:
 - Verificare se canali sovrapposti, canali non collegati che si incrociano, curvatura insufficiente.

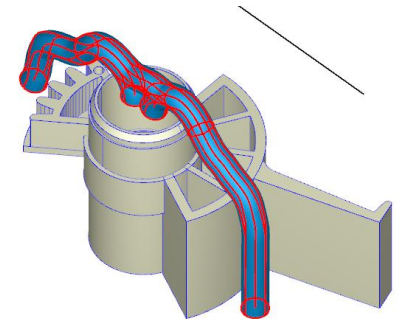
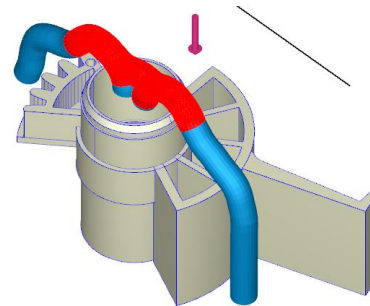
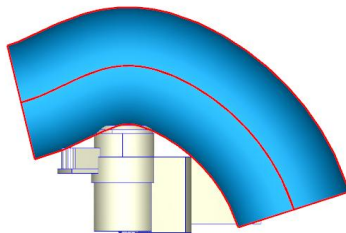
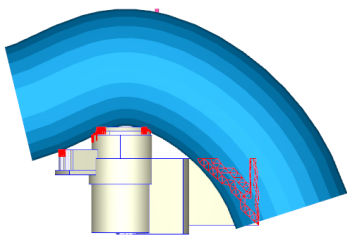

Conformal cooling wizard

- Miglioramenti degli algoritmi:
 - Evitare interferenze :

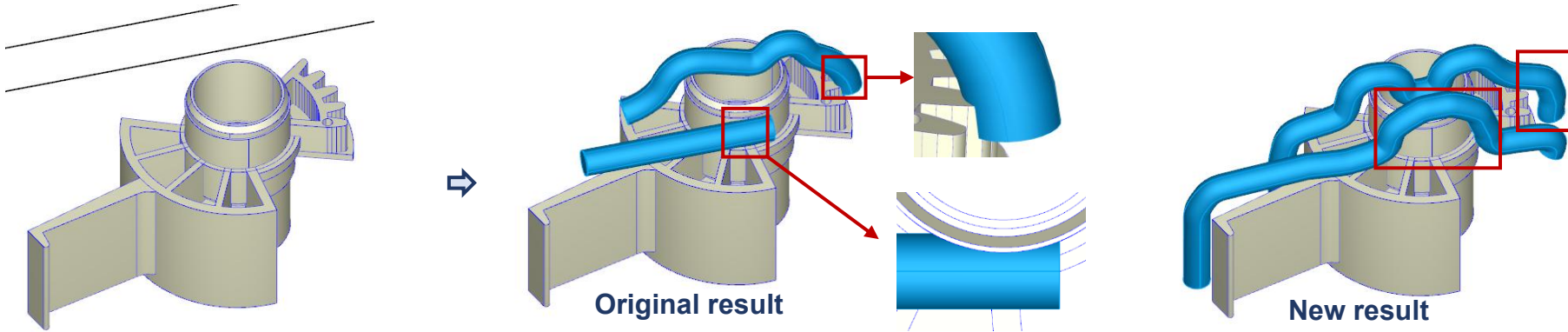

- Garantire la connessione al canale :

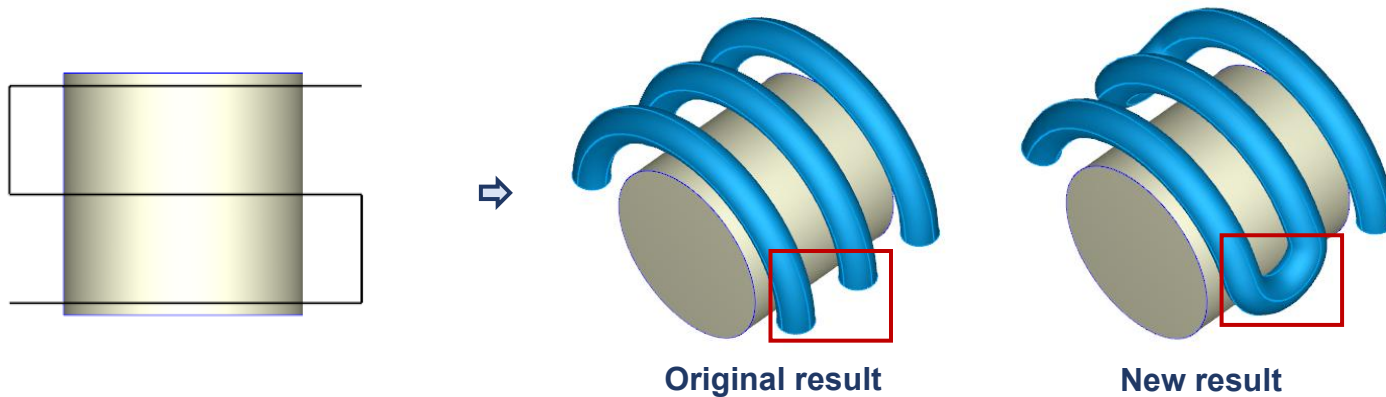

Conformal cooling wizard

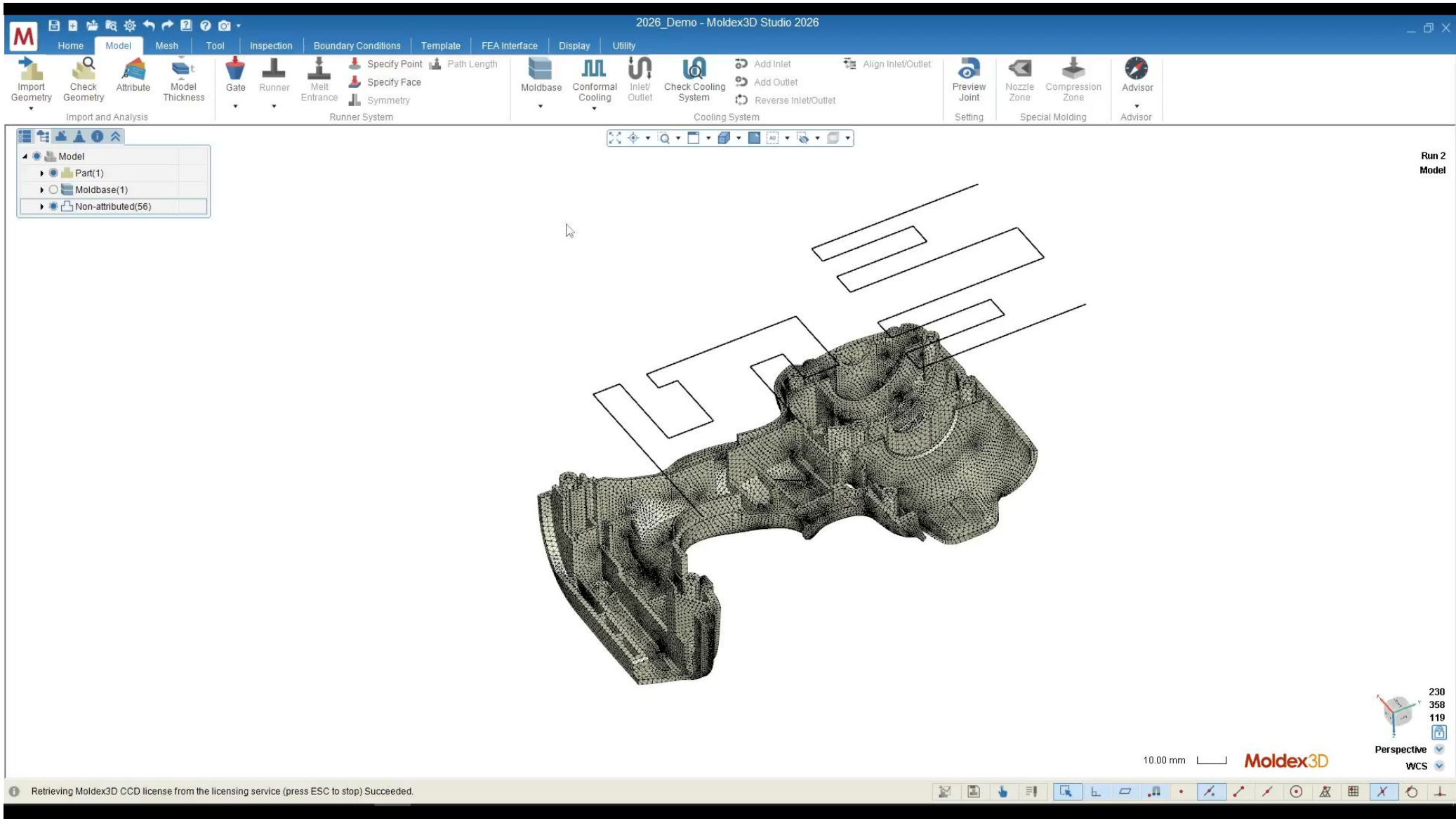

Enhanced cooling channel wizard

- Anteprima dei contorni:
 - Tratteggiato: nessun output
 - Solido: output
- Canali distribuiti uniformemente lungo il contorno.
- Distanza tra i centri del canale (C) determinato dal numero dei canali (N)
 - $Distanza (d) = lunghezza\ della\ linea \div numero\ di\ canali.$
 - Punzone e matrice calcolati separatamente.

Channel Parameters

D : 8.000 N : 12

C : 24.000 H : 16.000

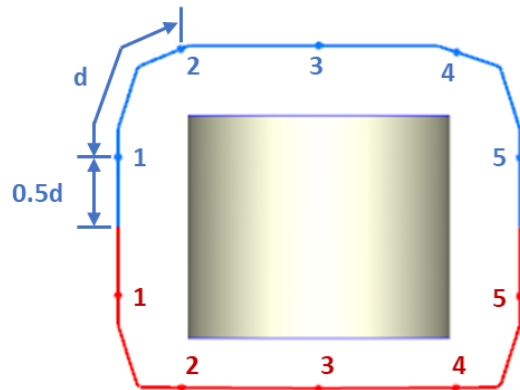

1. Linear Distribution (Default)

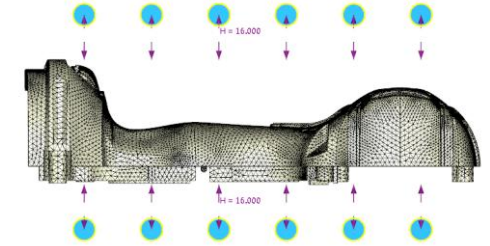
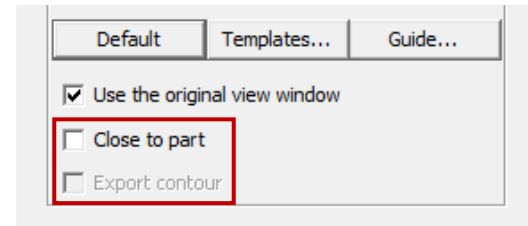

2. Close to Part

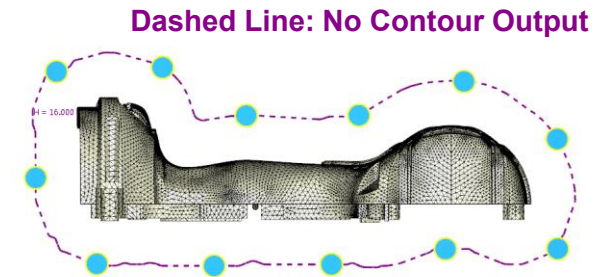
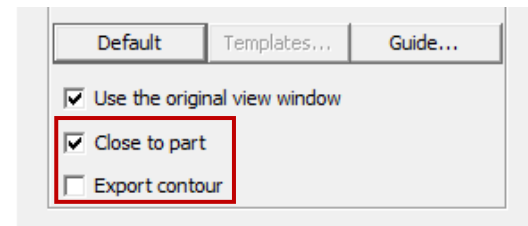

3. Close to Part with Contour Output

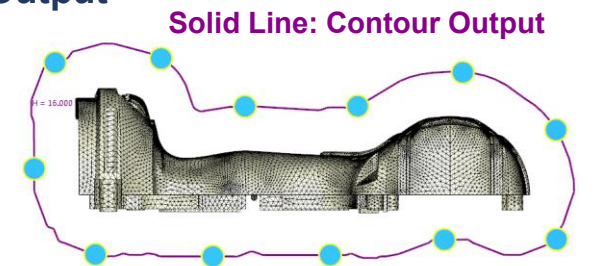
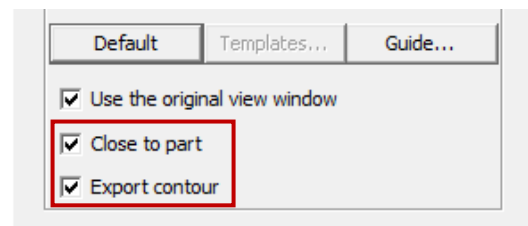

Enhanced cooling channel wizard

- Flusso di lavoro consigliato :

Create channels close to part with contour output

Select one set of channels to copy

Select a reference point

Copy channels to the target location

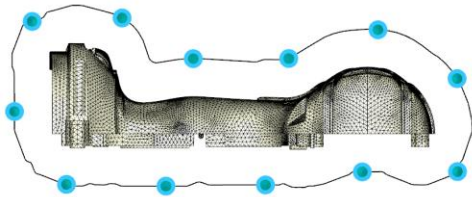

1. Select inlet and outlet points together

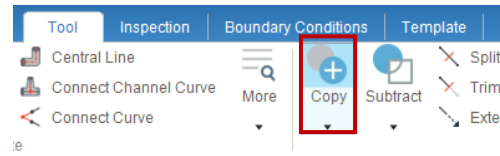
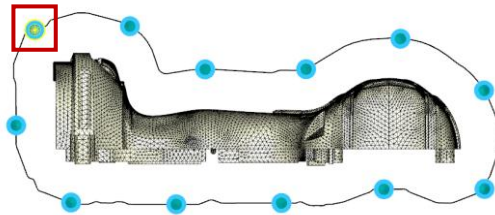

2. Enable snap to intersection.

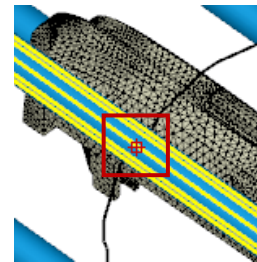

3. Quickly select channel-contour intersections.

4. Enable snap to near

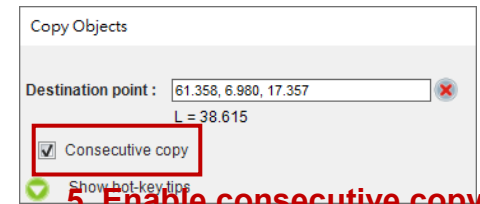
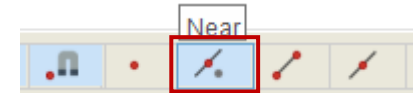

5. Enable consecutive copy.

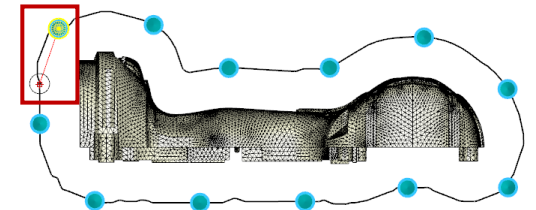

6. Copy channels to reinforce target location

Enhanced cooling channel wizard

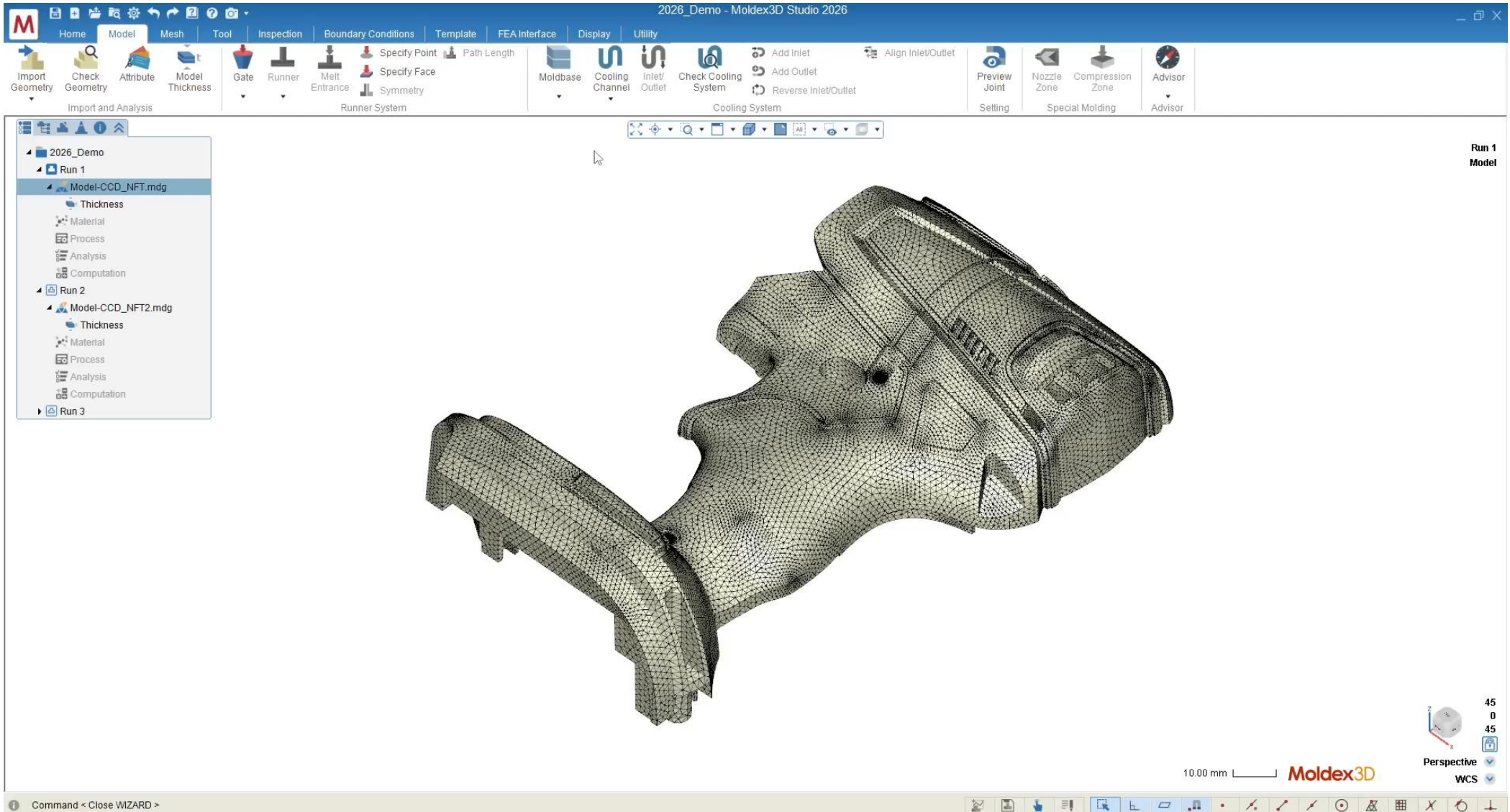

In conclusione, la simulazione dei sistemi di condizionamento si conferma uno strumento fondamentale per ridurre il tempo ciclo, migliorare l'uniformità termica e limitare difetti come deformazioni, ritiri non uniformi e tensioni residue.

Le funzionalità di Moldex3D, dal loop wizard dei canali di raffreddamento ai wizard per canali conformali insieme ad altri nuovi tool, permettono di progettare, verificare e ottimizzare in modo più rapido ed efficace anche le configurazioni più complesse.

GRAZIE DELL'ATTENZIONE

Thank you

The background features a dark, almost black, gradient. Overlaid on this are several thick, flowing, wavy bands of color. The primary colors are a deep, vibrant red and a dark, rich blue. These bands curve and sweep across the frame, creating a sense of motion and depth. The lighting is dramatic, with bright highlights along the edges of the waves, giving them a glossy, three-dimensional appearance. The overall effect is one of elegance and modernity.